



**Waukesha
Cherry-Burrell**

®

AN SPX BRAND

W I L L I A M S



CARVER CO.

Operation and Maintenance Manual Universal 420/520 Series Pumps

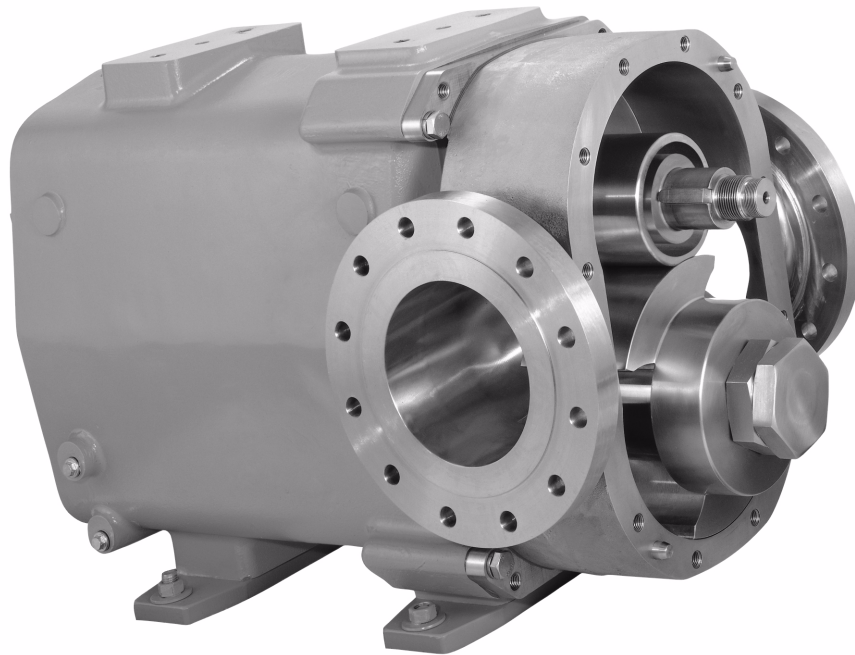

Read and understand this manual
prior to installing, operating or servicing this equipment.



®
AN SPX BRAND

611 Sugar Creek Road
Delavan, WI 53115 USA

Tel: (800) 252-5200 or (262) 728-1900

Fax: (800) 252-5012 or (262) 728-4904

E-mail: wcb@spx.com

Web site: www.spxpe.com



THE WILLIAMS - CARVER COMPANY, INC.

4001 MISSION RD P.O. BOX #3140

KANSAS CITY, KS 66103-0140

Office [913] 236-4949 Fax [913] 236-9331

www.williamscarver.com

Information contained in this manual is subject to change without notice and does not represent a commitment on the part of SPX Corporation. No part of this manual may be reproduced or transmitted in any form or by any means, electronic or mechanical, including photocopying and recording, for any purpose, without the express written permission of SPX Corporation.

Copyright © 2005, 2008 SPX Corporation.
All Rights Reserved.

Revision Date: July 2008

Publication: 95-03025

SAFETY

Warnings, cautions and notes are contained in this manual. To avoid serious injury and/or possible damage to equipment, pay attention to these messages.

WARNING Hazards or unsafe practices which COULD result in severe personal injury or death and how to avoid it.

CAUTION Hazards or unsafe practices which COULD result in minor personal injury or product or property damage.

NOTE Important information pertaining directly to the subject.
(Information to be aware of when completing the task.)

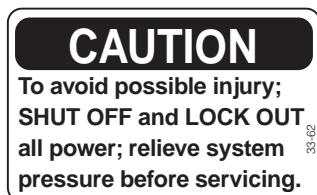
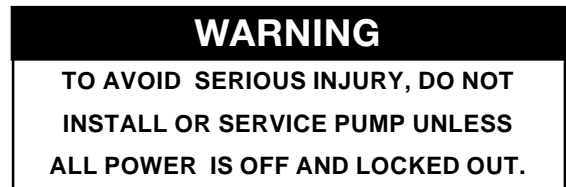
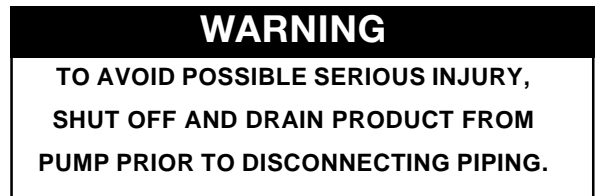
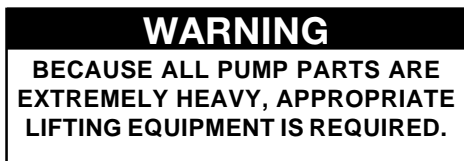

REPLACEMENT LABEL



REPLACEMENT LABEL

Read and understand this manual prior to installing, operating or maintaining this pump.

TABLE OF CONTENTS

| | | | |
|--|-------|--|----|
| Safety | 3 | Assembly Procedures | |
| | | Shaft Sub Assembly | 26 |
| | | Bearings | 26 |
| Receiving and Warranty | 5 | Shaft Installation in Gear Case Assembly 27-28 | |
| Inspection | | Timing Gear Installation | 28 |
| Loss or Damage | | Adjusting Rotor to Body Backface | 29 |
| Introduction | 6 | Shims - All Models | 29 |
| Installation | | Fluid Head Assembly | |
| Basic Dimensions | 7 | Seal Assembly | 30 |
| Capacity ratings | 7 | Body Installation | 31 |
| Pump and Drive Unit | 8 | Rotor Installation | 31 |
| Piping Layout | 9 | Cover Installation | 31 |
| Valves | 9 | Universal 420 Parts Listing | 32 |
| Strainers/Gages | 10 | Parts Listing | 33 |
| Alignment | 10-11 | Universal 520 Parts Listing | 34 |
| Pump Rotation | 11 | Parts Listing | 35 |
| Low Pressure Flush | 12 | Seals | |
| High Pressure Flush | 12 | Double Mechanical Seal | 36 |
| Start-up Check List | 13 | Single Inner Mechanical Seal..... | 37 |
| Operation | 14 | Single Outer Mechanical Seal | 38 |
| Lubrication | 14 | Parts Ordering | 39 |
| Cleaning | 14 | | |
| Troubleshooting a Pump System ... | 15-18 | Addendum (Aseptic/Steam Purge Models | 41 |
| Maintenance | | | |
| Safety Precautions | 19 | | |
| Special Tools | 19 | | |
| Disassembly Procedures | | | |
| Fluid Head Removal | 20 | | |
| Cover Removal | 20 | | |
| Rotor Removal | 21 | | |
| Body Removal | 22 | | |
| Mechanical Seal Removal | 23 | | |
| Gearcase Disassembly | | | |
| ... Timing Gears | 24 | | |
| ... Shaft and Bearing Removal | 25 | | |

RECEIVING AND WARRANTY

WAUKESHA CHERRY-BURRELL WARRANTY

Seller warrants its products to be free from defects in materials and workmanship for a period of one (1) year from the date of shipment. This warranty shall not apply to products which require repair or replacement due to normal wear and tear or to products which are subjected to accident, misuse or improper maintenance. This warranty extends only to the original Buyer. Products manufactured by others but furnished by Seller are exempted from this warranty and are limited to the original manufacturer's warranty.

Seller's sole obligation under this warranty shall be to repair or replace any products that Seller determines, in its discretion, to be defective. Seller reserves the right either to inspect the products in the field or to request their prepaid return to Seller. Seller shall not be responsible for any transportation charges, duty, taxes, freight, labor or other costs. The cost of removing and/or installing products which have been repaired or replaced shall be at Buyer's expense.

Seller expressly disclaims all other warranties, express or implied, including without limitation any warranty of merchantability of fitness for a particular purpose. The foregoing sets forth Seller's entire and exclusive liability, and Buyer's exclusive and sole remedy, for any claim of damages in connection with the sale of products. In no event shall Seller be liable for any special consequential incidental or indirect damages (including without limitation attorneys' fees and expenses), nor shall Seller be liable for any loss of profit or material arising out of or relating to the sale or operation of the products based on contract, tort (including negligence), strict liability or otherwise.

FACTORY INSPECTION

Each WAUKESHA pump is shipped completely assembled, lubricated and ready for use. The WAUKESHA pump is a precision product, designed to provide long, trouble-free service in a properly designed system with normal maintenance.

RECEIVING INSPECTION

Ports are rubber capped at the factory to keep out foreign objects. If covers are missing or damaged, a thorough inspection of fluid head, by removing pump cover, is recommended. Be sure pumping head is clean and free of foreign material before rotating shaft.

LOSS OR DAMAGE

If your pump has been lost or damaged in transit, file a claim at once with the delivering carrier and ask for an Inspector to call. The carrier has signed the Bill of Lading acknowledging that the shipment has been received from us in good condition.

We will of course assist you in every way in collecting claims for loss, or damage, however, we are not responsible for the collection of claims or replacement of material.

WARRANTY

Please read the Warranty statement to correctly determine if you have a claim. In warranty claims you must have a "Returned Goods Authorization" (RGA) from the manufacturer before any returns will be accepted. Your Distributor will help you in a warranty problem. (See back pages for Information required)

INTRODUCTION

The Models 420 & 520 provide reliable and accurate pumping at high-volume capacities. Every revolution of the Model 420 pumps more than a gallon and a half of product. Model 520, more than 2 gallons (9 liters).

Sanitation Features

- *Rotor/shaft connection sealed from product zone.*
- *Longer service life resulting from fresh engineering approach and high capacity components.*
- *Sidemount capability for better draining.*
- *The right seal for every application, plus interchangeability when needed.*
- *316L pump body standard.*
- *Metal rotor. exclusive Waukesha “88 “ non-galling alloy, for close running clearance.*
- *Exclusive, non-galling Waukesha “88” alloy rotors standard; permits running at tighter clearances and higher efficiencies; 316L stainless also available.*
- *Mechanical seals standard.*
- *Mechanical seal material options.*
 - *Carbon*
 - *Ceramic*
 - *Silicon Carbide*

Long-life features

- *Large diameter shafts in seal area for greater strength and stiffness.*
- *Heavy duty bearing frame (Gearcase)*
- *Double tapered roller bearings contribute further to precise rotor movement and longer seal life.*
- *No bearing in product zone - accommodates severe operating conditions.*
- *Greater flow capacity than conventional high-volume PD pumps.*
- *High pressure capability, up to 200 psi (13.7 bar) for more demanding jobs.*

Installation/Maintenance Flexibility

- *Bi-directional flow.* No flow direction specification needed.
- *4-Way mounting of gearcase,* including vertical alignment of ports.
- *Single-wing rotor option* for handling particulates
- *External shimming* simplifies shaft height adjustments; reduces downtime.
- *Upper or Lower shaft position.*
- *High-volume capacity with the reliability of a Waukesha*



INSTALLATION

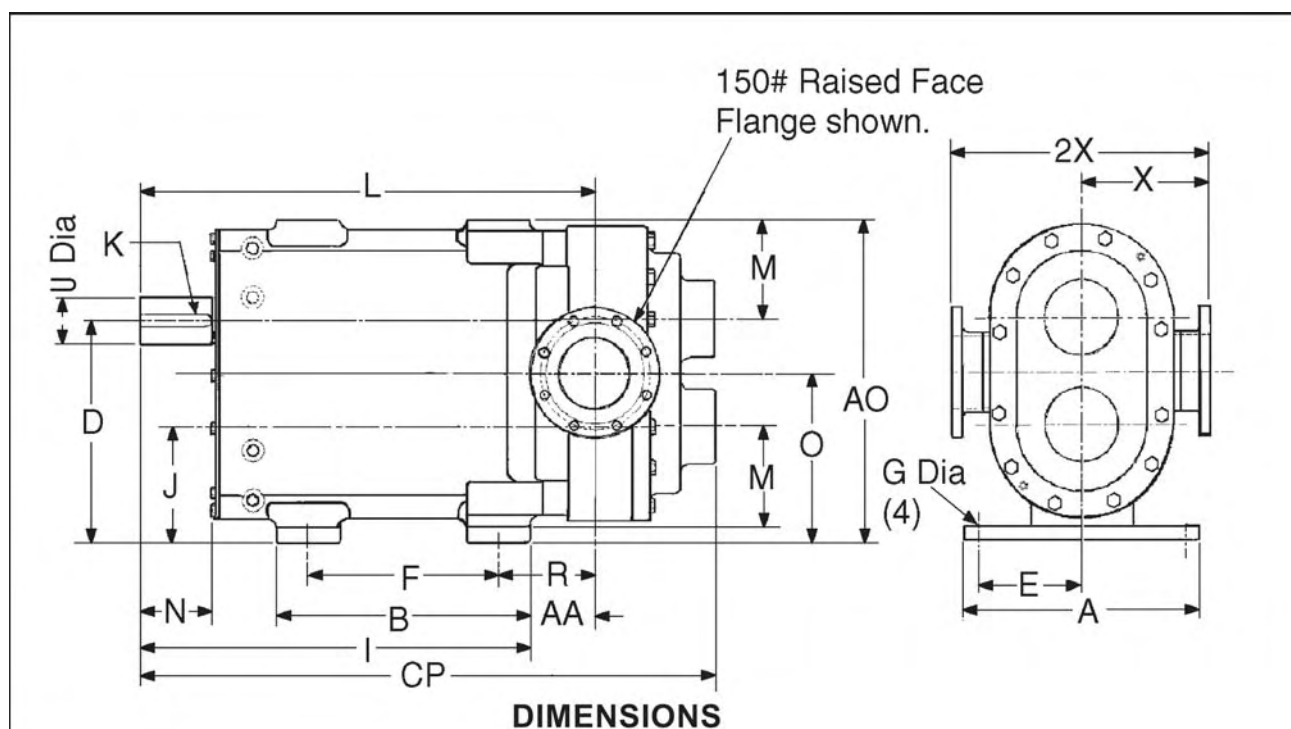

| MODEL | DIM. | A | AA | AO | B | CP | D | E | F |
|------------|------|-------|-------|-------|-------|--------|-------|-------|-------|
| 420 | inch | 21.00 | 5.62 | 27.25 | 22.00 | 49.60 | 18.75 | 7.50 | 16.50 |
| | mm | 533.4 | 142.7 | 692.2 | 558.8 | 1259.8 | 476.2 | 190.5 | 419.1 |
| 520 | inch | 21.00 | 5.82 | 27.25 | 22.00 | 51.42 | 18.75 | 7.50 | 16.50 |
| | mm | 533.4 | 147.8 | 692.2 | 558.8 | 1306.1 | 476.2 | 190.5 | 419.1 |

| MODEL | DIM | G | I | J | K | L | M | N | O | R |
|------------|------|-------|-------|-------|------|--------|-------|-------|-------|-------|
| 420 | inch | 1.06 | 33.60 | 9.75 | 1.00 | 39.22 | 8.50 | 6.09 | 14.25 | 8.37 |
| | mm | 26.92 | 853.4 | 247.6 | 25.4 | 996.2 | 215.9 | 154.7 | 362 | 212.6 |
| 520 | inch | 1.06 | 33.60 | 9.75 | 1.00 | 39.42 | 8.50 | 6.09 | 14.25 | 8.57 |
| | mm | 26.92 | 853.4 | 247.6 | 25.4 | 1001.2 | 215.9 | 154.7 | 362 | 217.7 |

| MODEL | DIM | U | X | 2X | FLANGE SIZE |
|------------|------|-------|-------|-------|-------------|
| 420 | inch | 3.875 | 11.25 | 22.50 | ANSI |
| | mm | 98.42 | 285.7 | 571.5 | 6" |
| 520 | inch | 3.875 | 11.25 | 22.50 | ANSI |
| | mm | 98.42 | 285.7 | 571.5 | 8" |

| MODEL | DISPLACEMENT PER REVOLUTION | NOMINAL CAPACITY TO | INLET OUTLET |
|------------|-----------------------------|----------------------------------|---------------|
| 420 | 1.62 GAL (6.13 LITER) | 650 GPM (147 M ³ /HR) | 6" (152.4 MM) |
| 520 | 2.38 GAL (9.00 LITER) | 830 GPM (187 M ³ /HR) | 8" (203.2MM) |

INSTALLATION

PUMP INSTALLATION

The installation of your Waukesha pump and its piping system should follow the practices described to give optimum performance, and be in accordance with local codes and restrictions.

All system equipment, such as motors, sheaves, drive couplings, speed reducers, etc., must be properly sized to insure satisfactory operation of your Waukesha pump within its limits.

CAUTION: Waukesha pumps are positive displacement, low slip design and will be severely damaged if operated with closed valves in discharge or inlet lines. Pump warranty is not valid for damages caused by a hydraulic overload from operation or start-up with a closed valve in the system.

WARNING

Full coupling guards must be installed to isolate operators and maintenance personnel from rotating components. Coupling guards are provided with Waukesha pumps as a part of a complete pump and drive package.

1. Installing the Pump and Drive Unit. Pumps of this type can be mounted on a common base plate with the drive. The unit can be installed in several ways:

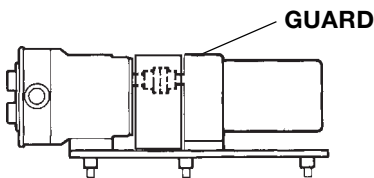

Adjustable leg base, commonly used for sanitary pumps. For washdown under base. Can be easily moved or repositioned.

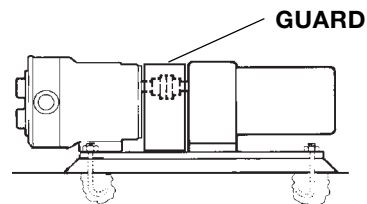

Permanent installation on foundation with bolts and grout. (Level unit before grouting.)

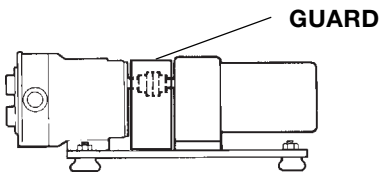

Leveling and/or vibration **isolation pads**.

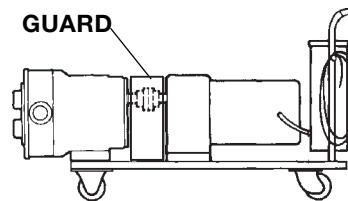

Portable bases-for movement to different locations. Many Commercial types are available.

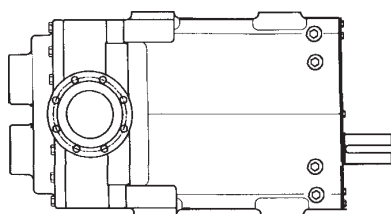

Bottom Shaft
Mount

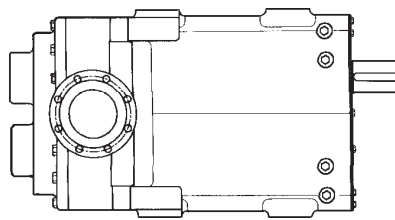

Top Shaft
Mount

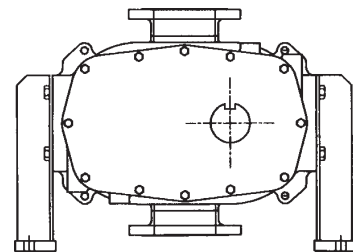

Sidemount
Vertical Fluid Entry

INSTALLATION

WARNING
TO AVOID SERIOUS INJURY, DO NOT INSTALL OR SERVICE PUMP UNLESS ALL POWER IS OFF AND LOCKED OUT.

2. Good Piping Practice.

All piping to the pump should be supported independently, to minimize the forces exerted on the pump. Such forces can cause misalignment of pump parts and lead to excessive wear of rotors, bearings and shafts.

NOTE: Pump dimensions and pump weights are on page 7.

A. Piping support:

Weight of piping and fluid-support piping independently with hangers or pedestals.



Thermal expansion of piping-can cause tremendous forces. Use thermal expansion joints to minimize forces on pump.

B. Flexible joints can also be used to limit the transmission of mechanical vibration. Anchor free ends of any flexible hose in system.

Piping Layout

C. Inlet side: Slope piping up to inlet to avoid air pocket.

D. Inlet side-use check valves to keep inlet line full, particularly with low viscosity fluids, and in start-stop operation.

E. Inlet Vacuum Service-use check valve on outlet side.

- Prevents backflow (air or fluid).
- Facilitates initial start-up (minimizes differential pressure pump must supply to start flow).

F. "Isolation" Valves-permit pump maintenance and removal safely and without emptying entire system.

G. Relief Valve

To protect the pump and piping system against excessive pressure, a relief valve should be installed. An integral relief valve, designed to bypass the fluid internally from the pump outlet to the inlet, should not be used on applications where the discharge must be closed for more than a few minutes. Prolonged operation of the pump with closed discharge will cause heating of the fluid circulating through the relief valve. When such operation is necessary, the relief valve, whether integral, attachable, or line-mounted, should discharge externally through piping connected to the fluid source, or if that is not practical, into the inlet piping near the source.

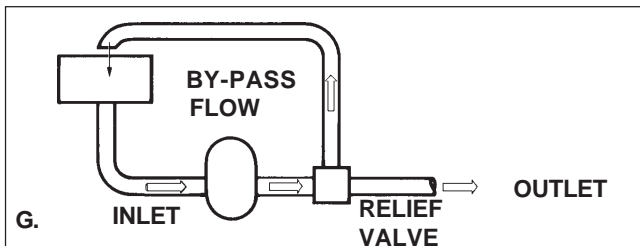
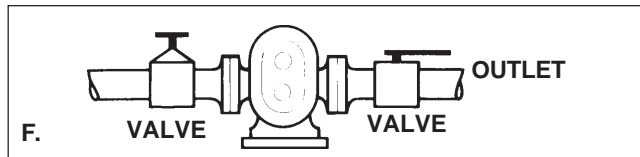
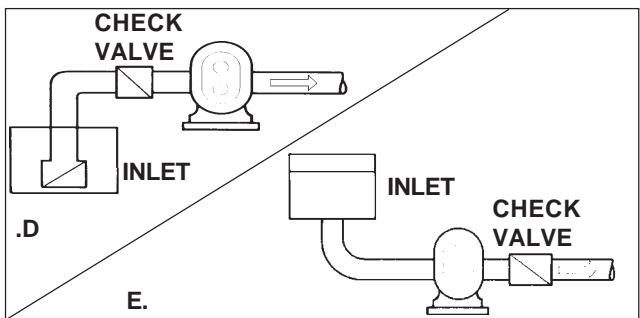
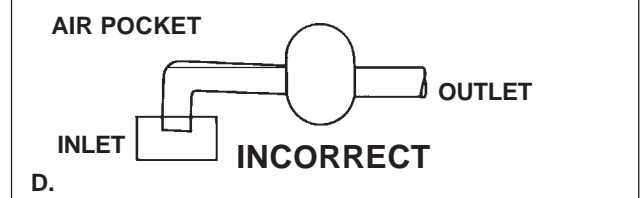
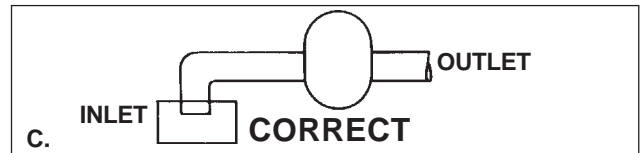
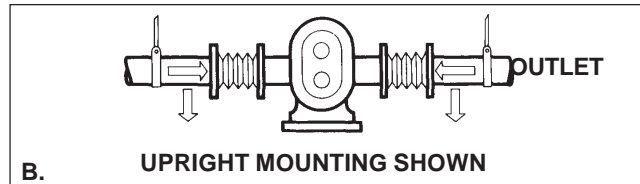
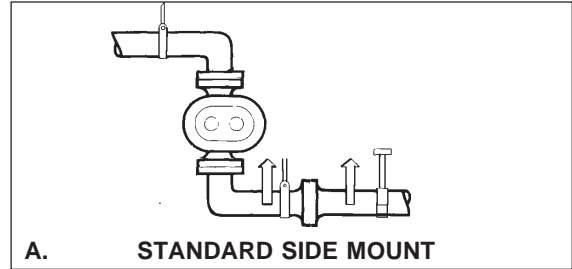

INSTALLATION

Inlet Side-Strainers and Traps.

Inlet side strainers and traps can be used to prevent pump damage from foreign matter. Selection must be carefully made as clogging can easily occur, restricting the inlet, causing cavitation and flow stoppage.

Pressure Gauges

Pressure and Vacuum gauges provide the easiest way to tell you something about the pump operation.

- Normal or abnormal pressures
- Overload conditions
- Indication of flow
- Changes in pump condition
- Changes in system conditions
- Changes in fluid viscosity

3. Alignment of Pump to Drive.

Pumps and drives which are ordered from the factory and mounted on a common base plate are accurately aligned before shipment. The alignment should be rechecked after the complete unit has been installed and the piping completed. Periodic rechecking is advisable during the pump service life.

In-line Drives. For initial pump installation, and for rechecking alignment, the following steps are advised:

Use a flexible coupling to connect the drive to the pump. Many different types are available, including couplings with slip or overload provision.



**RUBBER
CUSHIONED**

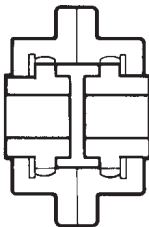

**GEAR
TYPE**

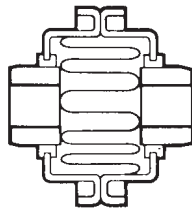

**FLEXIBLE
MEMBER**

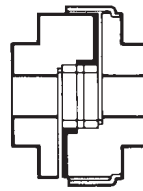

DETENT

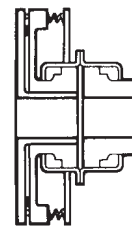

**SLIP
OVERLOAD**

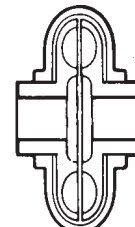

FLUID

A flexible coupling is used to compensate for end play and small differences in alignment. The pump and drive shaft should be aligned as closely as is possible.

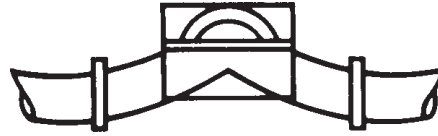

MAGNETIC TRAP

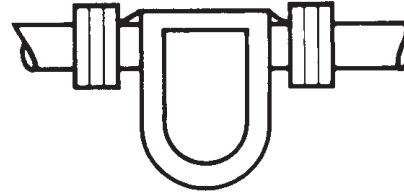

STRAINER

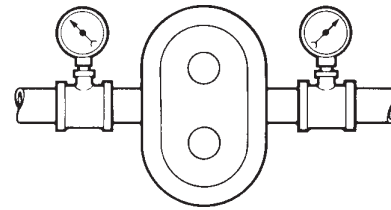

WARNING

**TO AVOID SERIOUS INJURY, DO NOT
INSTALL OR SERVICE PUMP UNLESS
ALL POWER IS OFF AND LOCKED OUT.**

INSTALLATION

Check angular alignment:

Using feeler gauges, or taper gauges, adjust to get equal dimension at all points. At the same time set space between coupling halves to manufacturer's recommended distance.

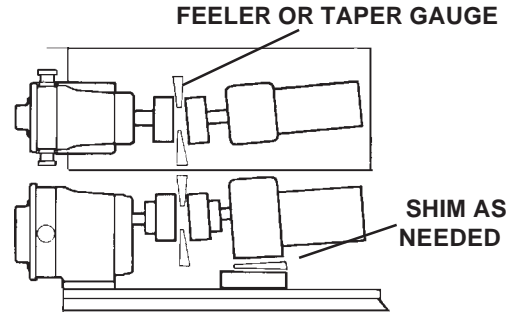

Check parallel misalignment: Use straight edges and shims:

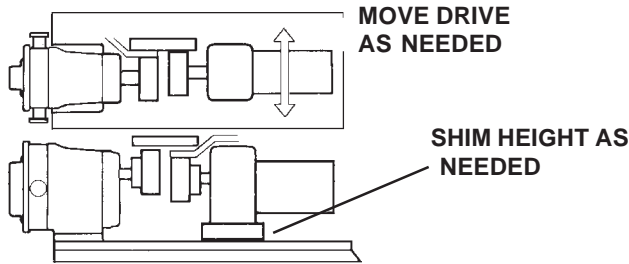

After piping is complete, and drive and couplings are aligned, turn pump shaft manually to see if it turns freely without binding.

Check rotation direction of drive to see that pump will rotate in proper direction. ("Liquid End" of pump is shown below.)

Warning Note: Covers have been removed for illustration purposes only. The pump *cannot* be operated with the cover removed.

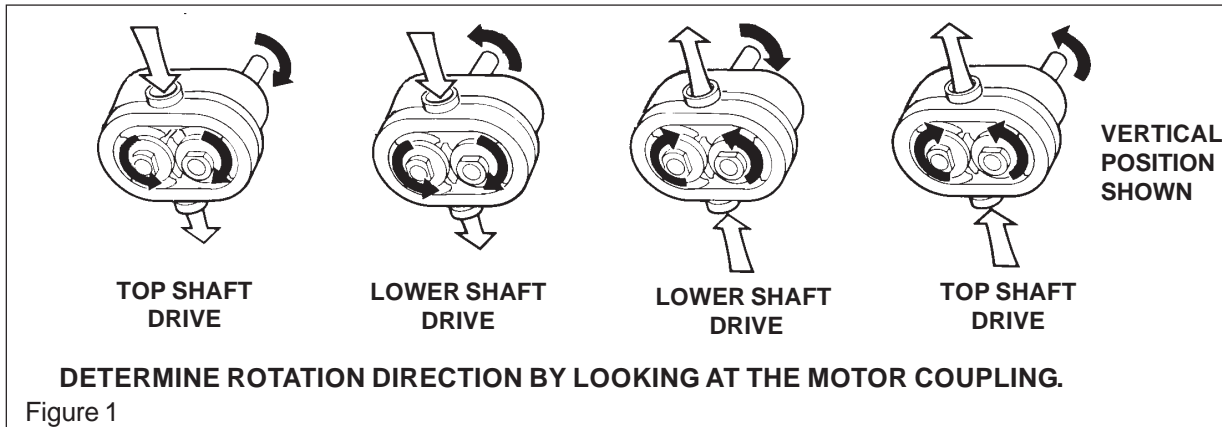
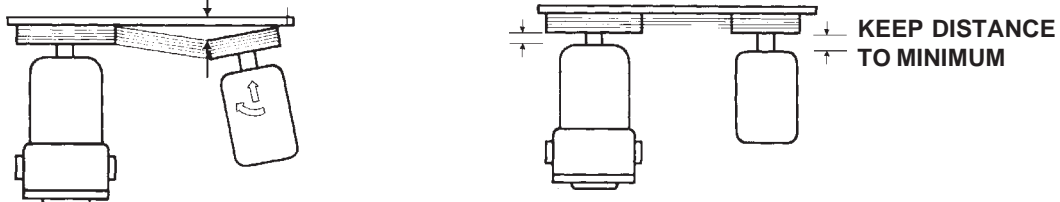

Figure 1

Aligning belt and chain drives. Using straight-edges and visual check: **MOVE DRIVE TO CORRECT ANGULAR AND PARALLEL MISALIGNMENT.**



After piping is complete and before belts are installed, **turn pump shaft manually** to see that it turns freely. Check rotation direction of pump to see that pump will rotate in proper direction (see figure 1) Install belts and tension them correctly. Install belt guard.

INSTALLATION

LOW PRESSURE FLUSH (STANDARD RECOMMENDATION)

a. Set flow rate of approximately 1/4 GPM for most applications. For high temperature applications, increase flow.

b. Flushing media is restricted on inlet side and has free flow to drain on outlet side.

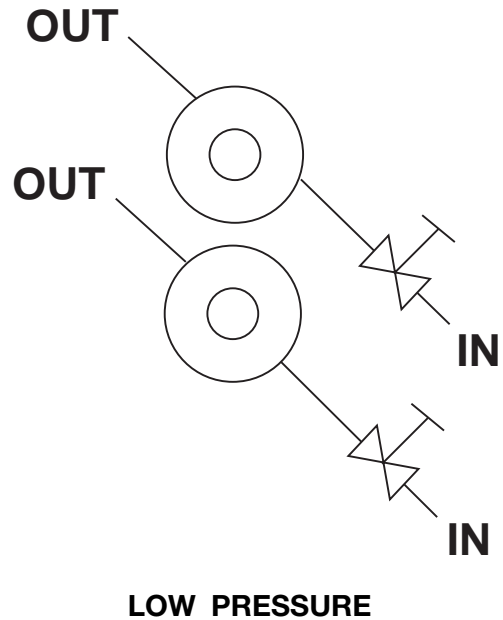

HIGH PRESSURE FLUSH

This method is good for abrasive applications and products that tend to "set" on seal faces.

a. Set flow rate of approximately 1/4 GPM for most applications.

Solenoid is recommended to stop flushing when pump is stopped. Restriction and pressure gauge is at discharge end. **Do not exceed 30 PSI with standard seals.**

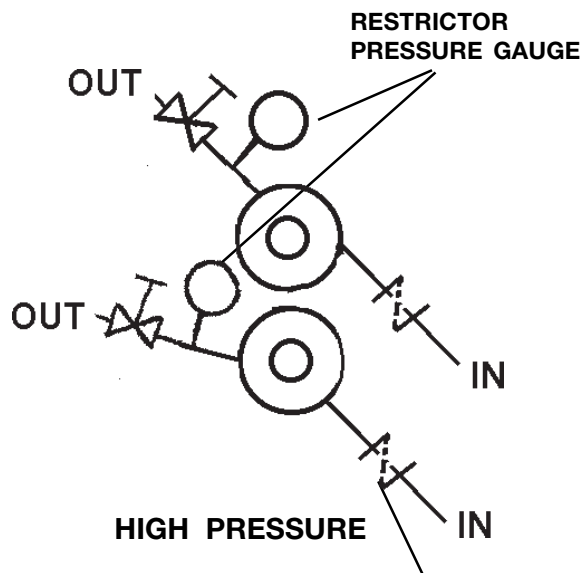

START-UP CHECK LIST

The Waukesha Pump is a positive displacement pump and thus can develop very high pressures. To protect lines, equipment and personnel, certain precautions must be taken.

1. Review page 9, particularly "Relief Valves". Install relief valves if needed.
2. Check that piping and pump are clean and free of foreign material, such as welding slag, gaskets, etc. **Do not use pump to flush system.**
3. See that all piping connections are tight and leak-free. Where possible, check system with "non-hazardous" fluid.
4. Check to see that pump and drive are lubricated. See page 14. Check Drive Lubrication Instruction.
5. Check that all guards are in place and secure.
6. Seals: Double mechanical and double O-ring seals with flushing require adequate supply and flow of clean flushing fluids.
7. See that all valves are open on discharge system, and that free flow path is open to destination.
8. See that all valves are open on inlet side, and that fluid can reach pump.
9. Check direction of pump and drive rotation. (See page 11)
10. Start pump drive. Where possible, start at slow speed, or jog.

Check to see that liquid is reaching pump within several minutes. If pumping does not begin and stabilize, check items under "No Flow" or "Insufficient Flow" on (Page 15)

Troubleshooting a Pumping System.

OPERATION

Normal operation covers a speed range of 0-600 RPM and pressure range of 0-200 PSI. Temperature range with standard rotors is -40° to 200° F. and with hot clearance rotors, 180° to 300° F. (For operation at higher temperatures, consult Waukesha Cherry-Burrell.)

See START-UP CHECK LIST (Page 13) and TROUBLESHOOTING (Page 15-18) for additional operation information.

LUBRICATION

The gears are factory lubricated with Micro-Plate No. 140 oil at the quantity shown for top or bottom shaft mounts. If you mount your pump other than top or bottom shaft drive, check oil level.

The bearings are factory greased with Micro-Plate #555 grease.

Change oil every 500 hours. If pump is installed where moisture and condensation are heavy, change oil more frequently.

Bearings must be greased every 250 hours or less depending on moisture and condensation conditions.

NOTE: For hot or cold extremes use appropriate lubricant as shown in the following tables.

| OIL |
|--|
| SAE 140 -10° to 350° F. (-23° to 177° C.) |

| GREASE |
|--|
| Silicone -20° to 5° F. (-29° to 15° C.) NLGI Grade 2 (5° to 350° F. (-15° to 177° C.) |

DRIVE LUBRICATION

Refer to drive manufacturer's manual shipped with unit.



CLEANING

The standard Waukesha pumps without CIP properties, are designed to be completely disassembled for thorough and easy cleaning.

Clean the pump every day or at the end of a process. Disassemble the fluid head as outlined. Remove and clean the cover O-ring, pump seals and rotor nut assembly. **Inspect and replace O-rings if required.**

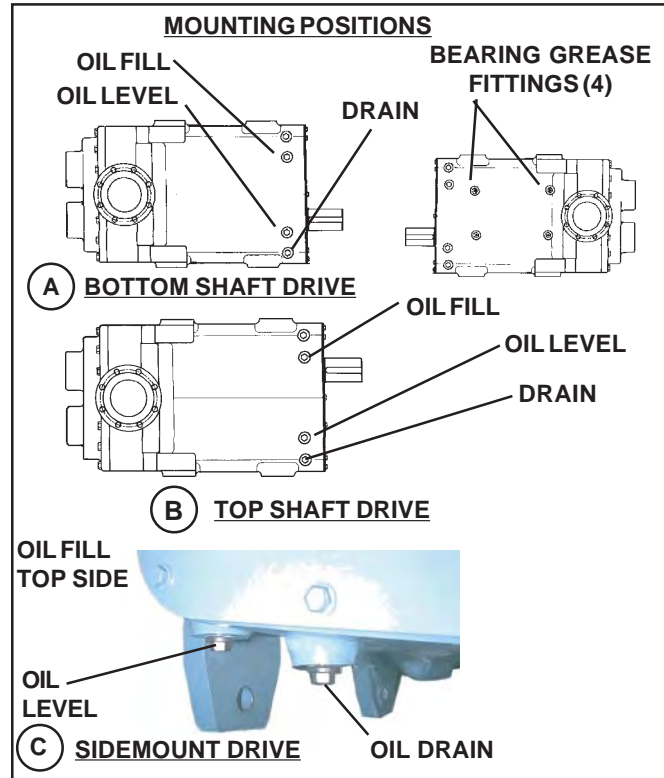

| MODEL | *OIL CAPACITY (GEARS) | |
|---------|-----------------------|-----------------------|
| | SHAFT | |
| | TOP OR BOTTOM | SIDE MOUNT |
| 420/520 | 3.0 Quart (3.4 Liter) | 4.7 Quart (4.5 Liter) |

* QUANTITIES SHOWN ARE FOR REFERENCE ONLY. ALWAYS FILL TO OIL LEVEL PLUG SHOWN.

NOTE:

Where possibility of material "setting up" during shut down exists, flushing with solvent or dis-assembly of fluid head and manual cleaning are required.

TROUBLESHOOTING A PUMPING SYSTEM

Once a pump is properly selected and installed in a system, operation should be trouble free. However, in existing systems, or as pump and system conditions change, problems may develop. Following are some troubleshooting hints to help identify and solve problems.

WARNING

TO AVOID SERIOUS INJURY, DO NOT INSTALL OR SERVICE PUMP UNLESS ALL POWER IS OFF AND LOCKED OUT.

WARNING

TO AVOID POSSIBLE SERIOUS INJURY, SHUT OFF AND DRAIN PRODUCT FROM PUMP PRIOR TO DISCONNECTING PIPING.

| Problem | Probable Causes | Solutions |
|---------------------------|---|--|
| No flow, pump not turning | Drive motor not running | Check resets, fuses, circuit breakers |
| | Keys sheared or missing | Replace |
| | Drive belts, power transmission components slipping or broken | Replace or adjust |
| | Pump shaft, keys, or gears sheared | Inspect: replace parts |
| No flow, pump not priming | Valve closed in inlet line | Open valve |
| | Inlet line clogged or restricted | Clear line, clean filters, etc. |
| | Air leaks due to bad seals or pipe connections | Replace seals; check lines for leakage (can be done by air pressure or by filling with liquid and pressurizing with air) |
| | Pump speed too slow | Increase speed. Filling inlet lines with fluid may allow initial start-up. Foot valve may solve start-up problems permanently. |
| | Liquid drains or siphons from system during off periods | Use foot valve or check valves |

TROUBLESHOOTING

| Problem | Probable Causes | Solutions |
|---|--|--|
| No flow, pump not priming | "Air" lock. Fluids which "gas off", or vaporize, or allow gas to come out of solution during off periods | Manual or automatic air bleed from pump or lines near pump |
| | Extra clearance rotors, worn pump | Increase pump speed, use foot valve to improve priming |
| | Net inlet pressure available too low | Check NIPA, NIPR~, recalculate system. Change inlet system as needed. |
| | On "Vacuum" inlet system: On initial start-up, atmospheric "blow back" prevents pump from developing enough differential pressure to start flow. | Install check valve in discharge line |
| Insufficient flow | Speed too low to obtain desired flow | Check flow-speed curve |
| | Air leak due to bad seals or pipe connections | Replace seals, check inlet fittings. |
| Fluid vaporization ("starved" pump inlet) | Strainers, foot valves, inlet fittings or lines clogged | Clear lines. If problem continues, inlet system may require change |
| | Inlet line size too small, inlet line too long. Too many fittings or valves. Foot valve, strainers too small . | Increase inlet line size. Reduce length, minimize direction and size changes, reduce number of fittings. |
| | NIPA too low | Raise liquid level in source tank |
| | NIPA too low | Increase by raising or pressurizing source tank |

NIPA - Net Inlet Pressure Available at Pump
NIPR - Net Inlet Pressure Required by Pump

TROUBLESHOOTING

| Problem | Probable Causes | Solutions |
|---|--|--|
| Fluid vaporization ("starved" pump inlet) | NIPA too Low | Select larger pump size with smaller NIPR |
| | Fluid viscosity greater than expected | Reduce pump speed and accept lower flow, or change system to reduce line losses. |
| | Fluid temperature higher than expected (vapor pressure higher) | Reduce temperature, reduce speed and accept lower flow or change system to increase NIPA |
| Insufficient flow. Fluid being bypassed somewhere | Flow diverted in branch line, open valve, etc. | Check system and controls |
| Insufficient flow. High slip | Hot (HC) or extra clearance rotors on "cold" fluid, and/or low viscosity fluid | Replace with standard clearance rotors |
| | Worn pump | Increase pump speed (within limits). Replace rotors, recondition pump. |
| | High pressure | Reduce pressure by system changes |
| Noisy operation | Cavitation | |
| | High fluid viscosity, High vapor pressure fluids, High temperature | Slow down pump, reduce temperature, change system |
| | NIPA less than NIPR see Engineering Manual | To increase NIPA or reduce NIPR, |
| | Air or gas in fluid | |
| | Leaks in pump or piping | Correct leaks |
| | Dissolved gas or naturally aerated products | Minimize discharge pressure. Also see "Cavitation" above. |
| | •Mechanical noises Rotor to body contact | |
| | Improper assembly | Check clearance with shims. See page 29. |

TROUBLESHOOTING

| Problem | Probable Causes | Solutions |
|---|--|---|
| Noisy operation | <ul style="list-style-type: none"> • Rotor to body contact Distortion of pump due to improper piping installation. | Reassemble pump or reinstall piping to assure free running |
| | Pressure higher than rated | Reduce pressure if possible |
| | Worn bearing | Rebuild with new bearings. Lubricate regularly |
| | Worn gears | Rebuild with new gears. Lubricate regularly |
| | <ul style="list-style-type: none"> • Rotor to rotor contact Loose or mis-timed gears. twisted shaft, sheared keys. worn splines | Rebuild with new parts |
| | <ul style="list-style-type: none"> • Drive component noise-gear trains, chains, couplings, bearings. | Repair or replace drive train |
| Pump requires excessive power (overheats, stalls. high current draw, breakers trip) | <ul style="list-style-type: none"> • Higher viscous losses than expected | If within pump rating, increase drive size |
| | <ul style="list-style-type: none"> • Higher pressure than expected | Reduce pump speed, increase line sizes |
| | <ul style="list-style-type: none"> • Fluid characteristics Fluid colder than expected. viscosity high | Heat fluid. insulate or heat trace lines. Use pump with more running clearances. |
| | Fluid sets up in line and pump during shut down | Insulate or heat trace line. Install "soft start" drive. Install recirculating bypass system. Flush with other fluid. |
| | Fluid builds up on pump surfaces (example. latex, chocolate. fondants) | Use pump with more running clearance |
| | "Short" pump service life | High corrosion rate |
| Pumping abrasives | | Larger pumps at slower speeds, can help |
| Speeds and pressures higher than rated | | Reduce speeds and pressures by changes in system |
| Worn bearings and gears due to lack of lubrication | | Set up and follow regular lubrication schedule |
| Misalignment of drive and piping. Excessive overhung load or misaligned couplings. | | Check alignment of piping. Check drive alignment and loads. (Page 11) |

MAINTENANCE

FLUID HEAD DISASSEMBLY

RECOMMENDED SAFETY PRECAUTIONS

- Completely flush all product and cleaning solutions from the pump fluid head before any component removal is started.
- Lock out, or disconnect all power sources to the pump drive motor before starting any work.
- Drain and (or) close off all inlet and discharge piping before disconnecting piping from fluid head.

WARNING
DO NOT OPERATE
WITHOUT GUARD IN PLACE

WARNING
Because all pump parts are
extremely heavy, appropriate
lifting equipment is required.

WARNING
TO AVOID POSSIBLE SERIOUS INJURY,
SHUT OFF AND DRAIN PRODUCT FROM
PUMP PRIOR TO DISCONNECTING PIPING.

SPECIAL TOOLS

Special tools are required to aid in the disassembly and reassembly of the fluid head. These tools are as follows:

420 UHC TOOL KIT #103996

| Item | Part No. | Description | Qty |
|------|----------|---------------------------|-----|
| 1 | 101423 | Shaft Extension Tool | 1 |
| 2 | 101418 | Rotor Lifting Device | 1 |
| 3 | 30-78 | Hex Hd Capscrew 1/2-13x1" | 2 |
| 4 | 30-360 | Eyebolt 1/2-13 x .75" ZP | 2 |
| 5 | 103985 | Guide Bolt 3/4-10 X 11" | 2 |
| 6 | 103986 | Seal Preload Tool | 1 |

520 UHC TOOL KIT #103998

| Item | Part No. | Description | Qty |
|------|----------|---------------------------|-----|
| 1 | 101423 | Shaft Extension Tool | 1 |
| 2 | 101418 | Rotor Lifting Device | 1 |
| 3 | 30-78 | Hex Hd Capscrew 1/2-13x1" | 2 |
| 4 | 30-360 | Eyebolt 1/2-13 x .75" ZP | 2 |
| 5 | 103985 | Guide Bolt 3/4-10 X 11" | 2 |
| 7 | 103987 | Seal Preload Tool | 1 |

420/520 TORQUE WRENCH KIT #103997

| Item | Part No. | Description | Qty |
|------|----------|-------------------------------|-----|
| 8 | 105908 | 3/4" Drive Torque Wrench | 1 |
| 9 | 103989 | Adapter Socket Drive 3/4 x 1 | 1 |
| 10 | 103990 | Adapter Socket Drive 1 x 1.5" | 1 |
| 11 | 103991 | Drive Socket, 4-1/2" | 1 |
| 12 | 108788 | Drive Socket, 4" Hex | 1 |

- 1000 pound capacity hoist and suitable lifting straps or chains.

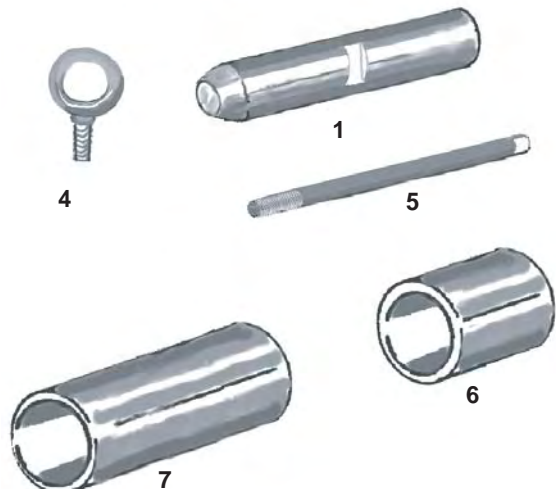
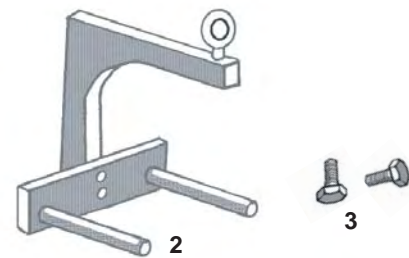
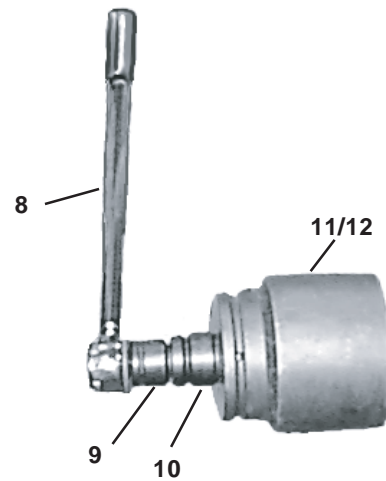

MAINTENANCE

FLUID HEAD COVER REMOVAL

WARNING

Because all pump parts are extremely heavy, appropriate lifting equipment is required.

NOTE: THE FLUID HEAD COVER WEIGHS APPROXIMATELY 200 POUNDS. LIFTING EQUIPMENT IS REQUIRED.

1. Install an eye bolt into the tapped hole at the top of the cover (or at both ends if the pump is side mounted.).
2. Position the hoist over the fluid head and attach it to the eye bolt(s) on the cover. Apply light lifting load to the cover.
3. Remove the cover bolts
4. Install two (2) guide bolts thru cover using holes near the eye bolt locations.
5. Install two (2) 1/2-13 bolts in the tapped holes over the cover dowel pins. Break the cover loose from the dowel pins by alternately tightening the 1/2" bolts.
6. Support the cover with the hoist and remove it from the fluid head.
7. Remove the 1/2" bolts from the cover.
8. Remove the guide bolts from the fluid head.
9. Clean and inspect the cover, O-ring, and all bolts for signs of wear or damage. Repair or replace any questionable component.

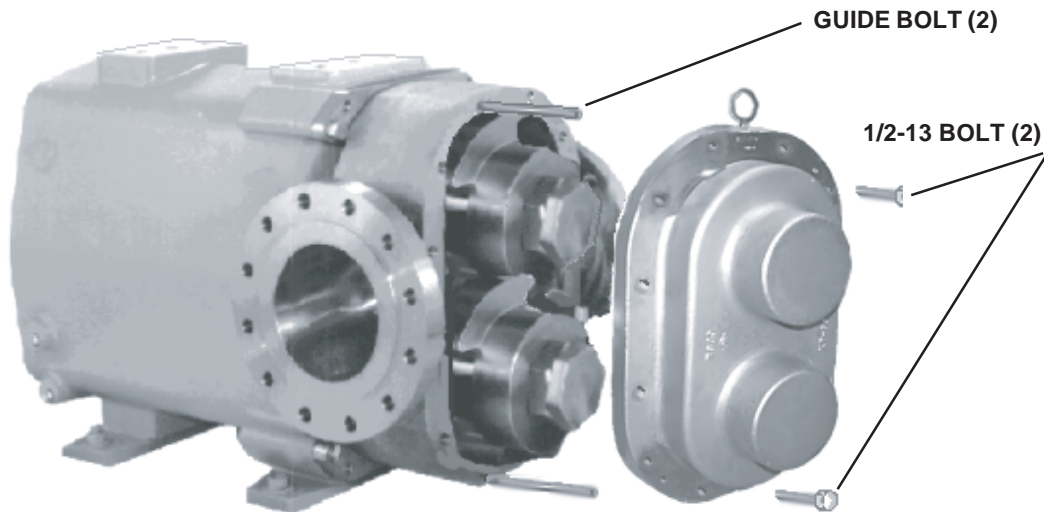

COVER REMOVAL

MAINTENANCE

FLUID HEAD DISASSEMBLY ROTOR REMOVAL

NOTE: THE MODEL 420 ROTOR WEIGHS APPROXIMATELY 80 POUNDS. MODEL 520 ROTOR WEIGHS APPROXIMATELY 100 POUNDS. LIFTING EQUIPMENT IS RECOMMENDED.

1. Remove fluid head cover as described by the fluid head cover removal procedure in the previous section.
2. Use a block that will not mark the rotors to limit the rotation of the rotors during rotor nut removal. *This may be a 2"x 2"x8" long piece of wood (or equal).*
3. Remove the outer (encapsulated) jam nut and the inner rotor retaining nut from both shafts using the torque wrench and socket or other suitable wrench.
4. Install the shaft extension tool on the shaft whose rotor is to be removed and slide the rotor out of the body and out onto the extension. Using the hoist and rotor lifting device, remove the rotor from the extension.
5. Move the extension to the other shaft and remove the other rotor from the fluid head.
6. Mark all components so that they can be reinstalled on the same shafts that they were removed.
7. Remove the rotor drive keys from the shafts.
8. Clean and inspect the components for wear or damage and repair or replace any questionable components.

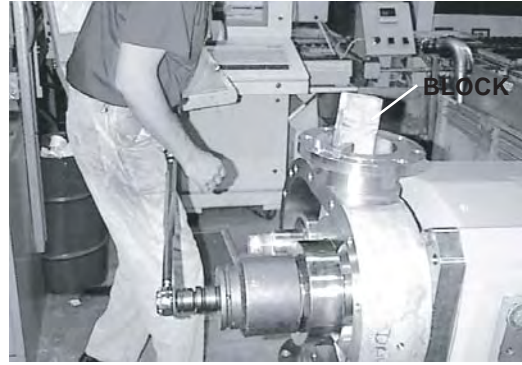

LOOSEN ROTOR NUTS

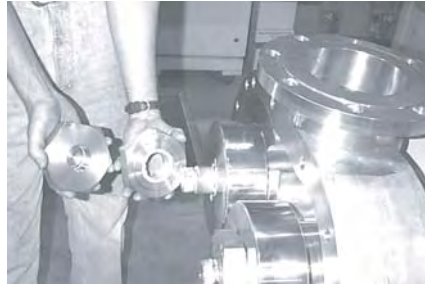

REMOVE ROTOR NUTS

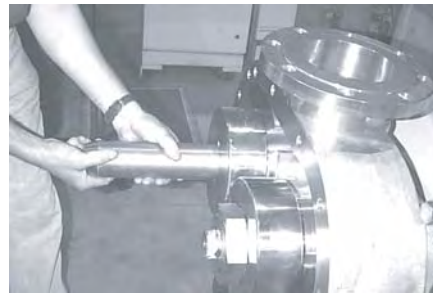

ATTACH EXTENSION



SLIDE AND POSITION ROTOR



USE ROTOR REMOVAL TOOL TO REMOVE ROTORS

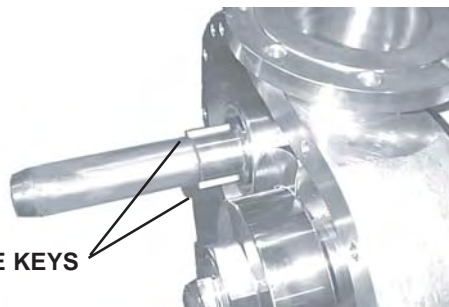

REMOVE KEYS

MAINTENANCE

FLUID HEAD DISASSEMBLY BODY REMOVAL

NOTE: THE MODEL 420 BODY WEIGHTS APPROXIMATELY 650 POUNDS. THE MODEL 520 BODY WEIGHTS APPROXIMATELY 720 POUNDS. LIFTING EQUIPMENT IS REQUIRED.

1. Remove the fluid head cover and rotors as described in the preceding procedures.
2. Disconnect the inlet and discharge piping from the pump body.
3. Remove the twelve (12) 5/16" seal seat retaining bolts from the back side of the pump body.
4. Loosen, but do not remove, the four (4) 3/4" body mounting plate retaining bolts.
5. Position the hoist over the fluid head and secure it to the pump body and apply lifting tension to the body. Two 1/2-13 tapped holes are provided at the top and bottom (depending on mounting position) for use with eye bolts to aid in lifting
6. Remove the four (4) 3/4" retaining bolts and loosely install them into the tapped holes in the fluid head mounting plate.
7. Install two (2) 3/4-10 x 11" long guide bolts into the two retaining bolt holes.
8. Alternately tighten the body retaining bolts to disengage the body dowel pins from the gearcase and **carefully** slide the body away from the shaft mounted mechanical seals.
9. Remove the body from the gearcase with the hoist, after clearing the mechanical seals.
10. Clean and Inspect the components for wear or damage and repair or replace questionable parts.

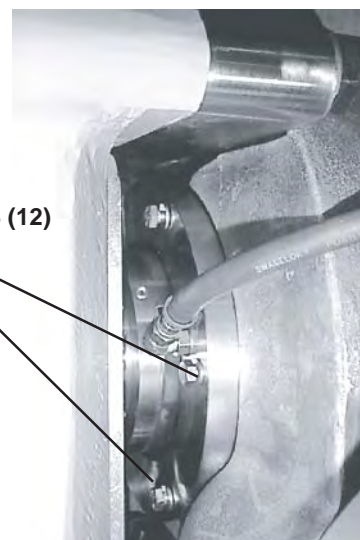

SEAL SEAT
RETAINING BOLTS (12)

PLACE RETAINING
BOLTS (4) HERE

GUIDE BOLT (2)

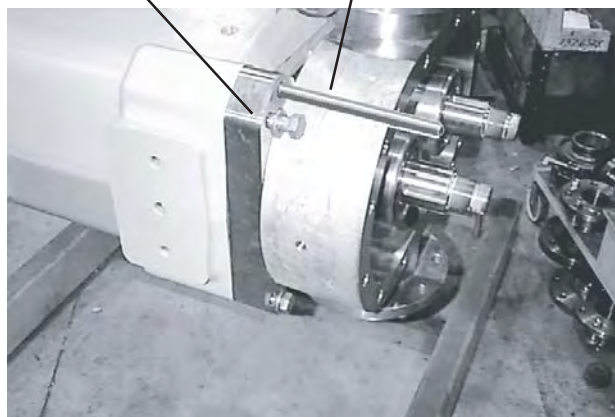

PUSH BODY OFF GEARCASE

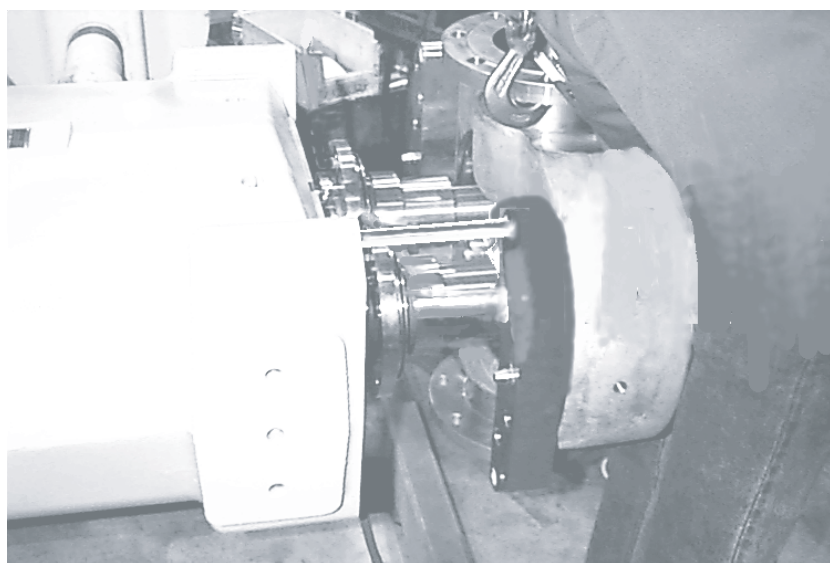

BODY REMOVAL

MAINTENANCE

FLUID HEAD DISASSEMBLY

MECHANICAL SEAL REMOVAL

NOTE: THE MECHANICAL SEALS ARE NOT HEAVY; HOWEVER, THEY ARE EXPENSIVE, AND ARE SOMEWHAT FRAGILE.

1. Remove the cover, rotors, and body as described in the previous procedures.
2. Disconnect the flush tubes from the seal seat gland plate if this has not already been done.
3. **Slip the inner seal preload tool over the end of the shaft.**
4. Install the rotor retaining nut, and hand tighten it against the preload tool and shaft shoulder.
5. Remove the setscrews in the inner seal seat retainer.
6. Remove the rotor retaining nut and preload tool.
7. Remove the inner seal seat retainer.
8. Inspect the shaft and remove burrs caused by the setscrews before removing the inner seal and inner seal O-ring to avoid causing damage to either component.
9. Remove the T-seal and gland plate.
10. Remove the inner seal.

FLUSH TUBES

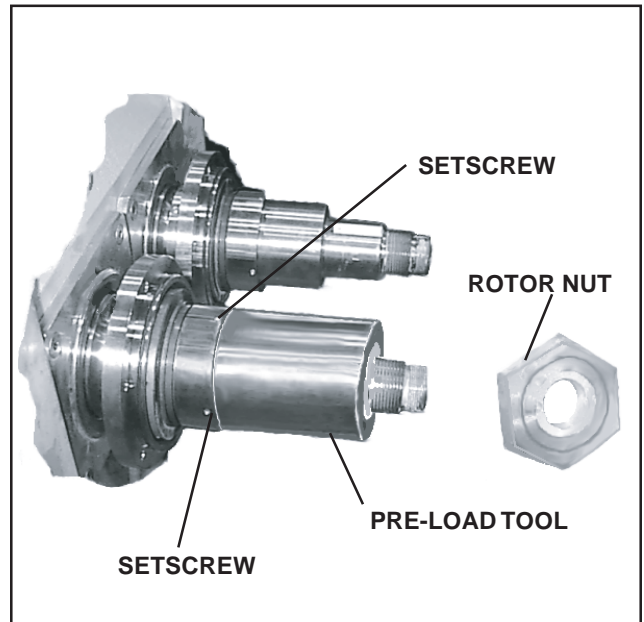
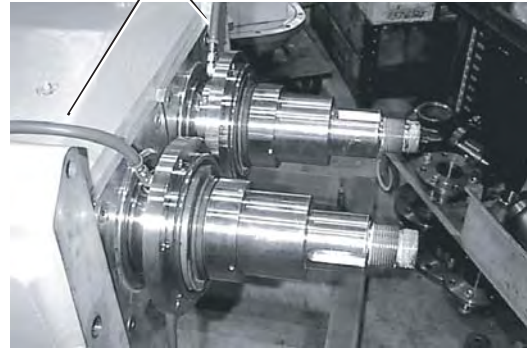

Double Mechanical Seal

11. Remove the outer seal setscrews and slide the outer seal assembly off the shaft

Inspect all components for wear or damage and repair or replace any questionable parts.

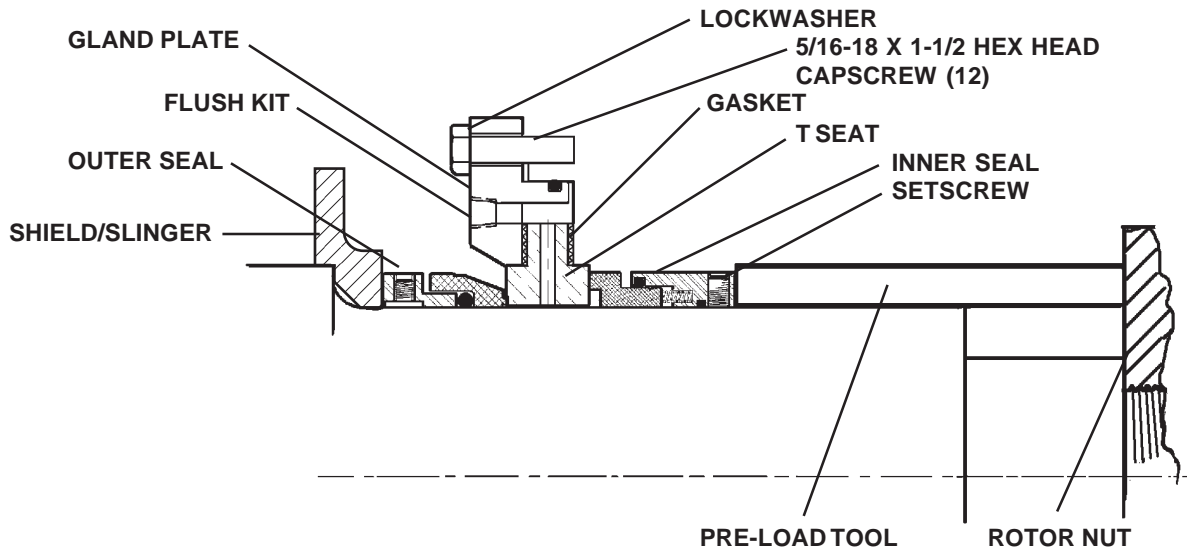

MAINTENANCE

GEARCASE DISASSEMBLY

CAUTION NOTE: THIS PROCEDURE IS BEST PERFORMED AT A PROPERLY EQUIPPED SERVICE FACILITY. THE COMPONENTS ARE LARGE, HEAVY, AND IN MOST CASES REQUIRE SPECIAL TOOLS AND LIFTING EQUIPMENT.

TIMING GEARS

1. Drain the gear lubricant from the drive end of the gearcase.
2. Remove the twelve (12) hex head cap screws from the timing gear cover, and remove the cover.

3. The timing gears are retained with locknuts and lockwashers. Using a hammer and punch, disengage the lockwasher locking tabs from the mating notches in the locknuts.

The locknuts and lockwashers may now be removed.

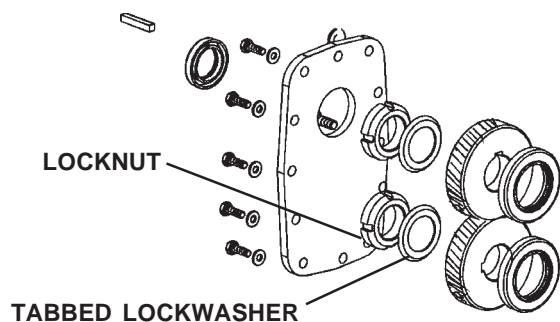
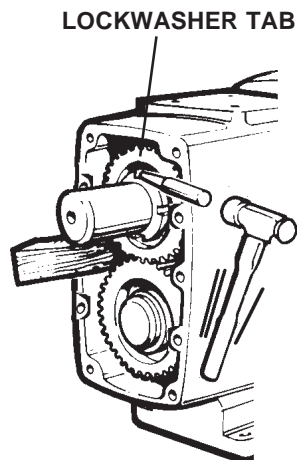

(Note: The locknuts were installed with a minimum of 600 foot-pounds of torque using a special spanner type socket. A shaft locking device was also used to keep the shafts from rotating during the tightening operation.)

4. Remove the timing gears and the timing gear keys. The gears should slide off the shafts. If a gear puller is required, three tapped holes are provided in each gear for that purpose.

5. With the gears removed, install a spacer (same length as the gear width (3")) and reinstall the bearing nut. The nut needs to be only hand tight, but, fully engaged on the shaft threads. This prevents the shaft assembly from prematurely disassembling during the removal from the gearcase.

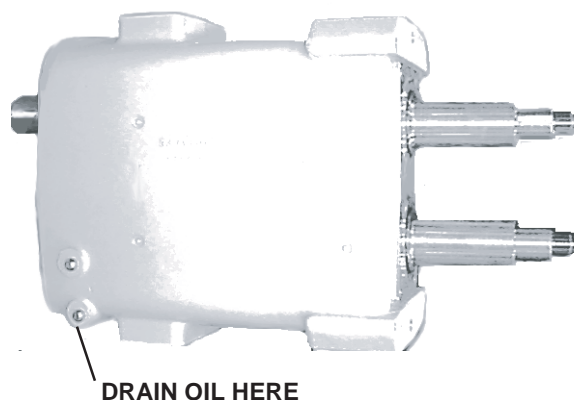

MAINTENANCE

GEARCASE DISASSEMBLY

BEARING REMOVAL

The recommended position for the gearcase would have shafts up .

Bearing Retainer

6. Remove the four front bearing retainer screws from each front bearing retainer, and remove the front bearing retainers.

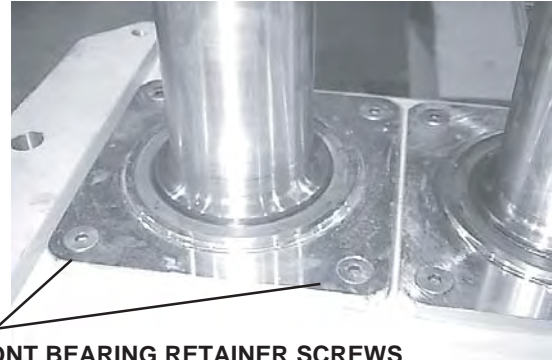

FRONT BEARING RETAINER SCREWS

Shaft Assemblies

7. The shafts may now be removed from the gearcase. Screw the shaft lifting extension tool onto shaft. Use proper size hoist to lift.

WARNING
Shaft assemblies weight approximately 350 pounds each.

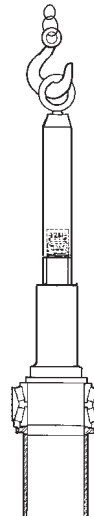

SHAFT ASSEMBLY REMOVAL WITH TOOL

BEARING SEATS, SHIMS AND SEALS

8. Remove the front bearing seats and any shims from the front bearing bores.
9. Remove the rear bearing seals from the rear bearing bores of the gearcase.
10. Clean and inspect all components for wear or damage.

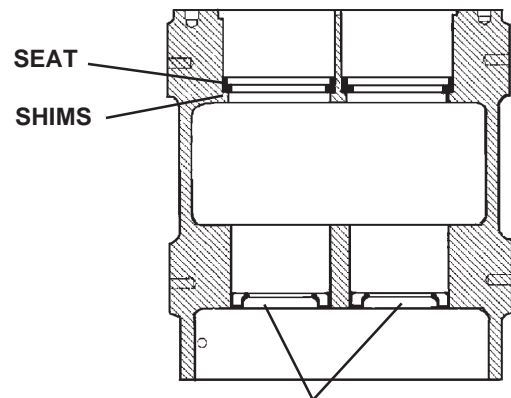

REAR BEARING SEALS

Bearings

Removal of the bearings from the shafts will require a large bearing press and an experienced operator.

The bearings are fitted to the shaft with a .0015"/.0025" interference fit, and must be pressed off. This is only required if the bearings are defective and the shaft is to be saved.

(Note: If the shaft is defective, the bearings will be lost during removal; therefore, this entire operation should be avoided.)

MAINTENANCE

GEARCASE ASSEMBLY

SHAFT SUBASSEMBLY PROCEDURE

1. Position the shaft in a fixture with the drive end down.
2. Use a bearing heater to heat a front and rear bearing to 300° F. (Do not exceed this temperature.)
3. Install the front bearing (14) on the shaft. Make sure that it is fully seated against the shaft shoulder.
4. Install the front bearing rear seal (12) on the shaft. This component is symmetrical; Therefore, it can be mounted either way.
5. Install the bearing spacer (11) on the shaft. This component is symmetrical; Therefore, it can be mounted either way.
6. Install the rear bearing inner seal (9) on the shaft. Make sure that the turned hub on the inner seal engages the bearing spacer.
7. Install the rear bearing (14) on the shaft.
8. Install the gear spacer on the shaft.
9. Using a timing gear, seat all components, and allow the bearings to cool.
10. Remove the timing gear, and install a spacer and the bearing nut. This will secure all components during assembly into the gearcase. (Several gear spacers may be used if a designated gear spacer is not available.)
11. Repeat steps 1 through 9 for the other shaft.

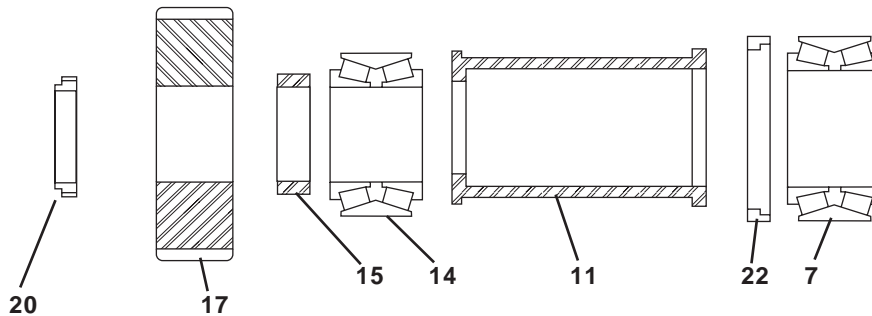
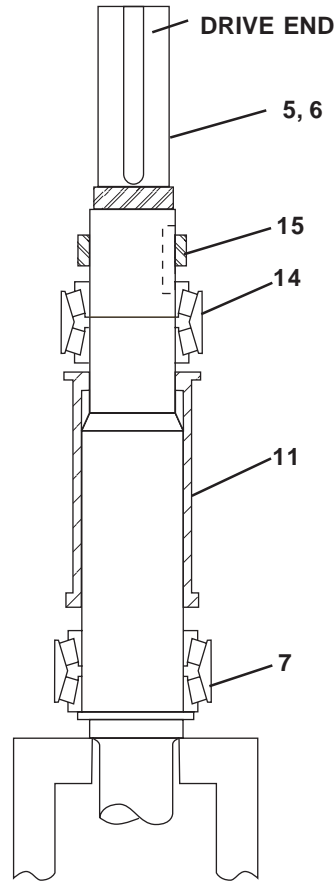

ITEM

| ITEM | PART NO. | DESCRIPTION | ITEM | PART NO. | DESCRIPTION |
|------|----------|--------------------------|------|-------------|------------------------|
| 5 | 100432 | TIMING GEAR, DRIVE SHAFT | 14 | 100429 | REAR BEARING |
| 6 | 100433 | TIMING GEAR, SHORT SHAFT | 15 | 100430 | GEAR SPACER |
| 7 | 100425 | FRONT BEARING | 20 | STD 236 022 | LOCKNUT, BEARING AN-22 |
| 11 | 108178 | BEARING SPACER | 22 | 100435 | FRONT BEARING SEAT |

MAINTENANCE

GEARCASE ASSEMBLY

INSTALLATION OF SHAFTS INTO THE GEARCASE.

1. Mount the gearcase vertically with the fluid head mounting surfaces up.
2. Install a front bearing seat (Item 22, page 33 & 35) in each of the front bearing bores of the gearcase.
3. Using a hoist and special lifting tool, lift a shaft and carefully slide it into the gearcase.
4. Repeat this step for the other shaft. *Locate the drive shaft according to your drive need.*

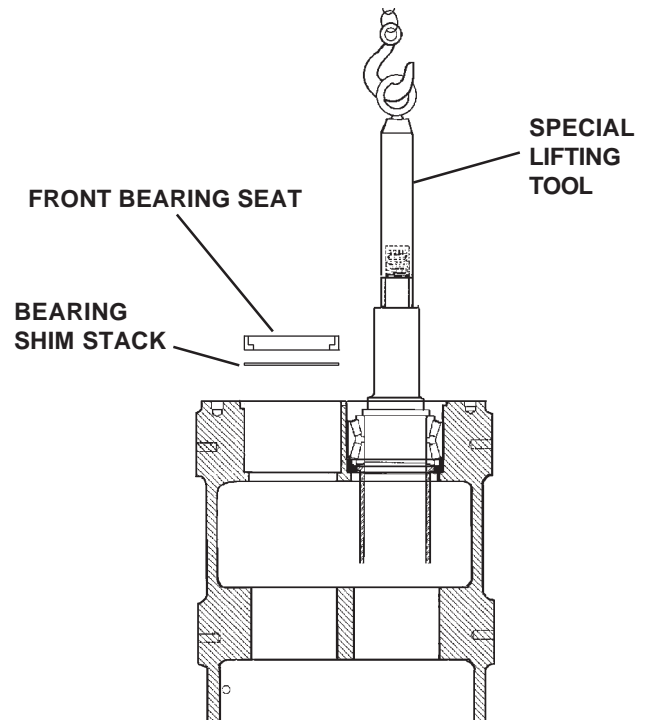

5. Before continuing, a critical measurement must be taken to determine the need for a bearing shim. measure the distance between the fluid head mounting surface and the rotor seat surface on the corresponding shaft. Do this for both shafts. If both dimensions are the same, then no shims are needed. If there is a difference, then a shim must be added to the shaft assemble with the shortest dimension. The thickness of the shim is equal to the difference between the two measurements.
6. If a shim is required, it must be added at this time. Remove the appropriate shaft and the front bearing seat, and place the required shim(s) in the front bearing bore. Then reinstall the front bearing seat and shaft assembly.
7. Recheck the measurement made in step 5. Allowable differences between the two shafts will be $\pm .001$ ".



MEASURE BOTH SHAFT S. APPLY SHIM UNDER FRONT BEARING SEAT, IF REQUIRED.

MAINTENANCE

GEARCASE ASSEMBLY

INSTALLATION OF SHAFTS INTO THE GEARCASE.

8. Apply bearing lubricant to the shafts at the front seal location to aid in installation of the seal. Apply silicone sealant to the front bearing retainers. Install the front bearing retainers (P/N 100441) and seals (P/N 100442).

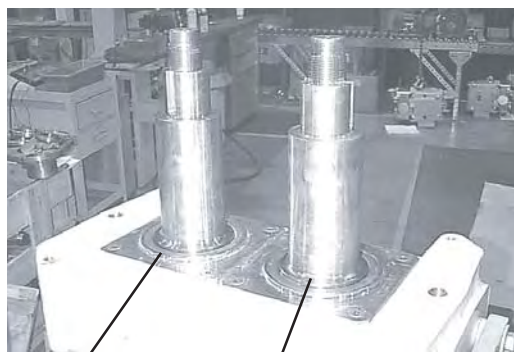

FRONT BEARING RETAINER

FRONT BEARING RETAINER SEAL

TIMING GEARS

9. Turn the gearcase over to expose the timing gear end of the housing and remove the locknuts and temporary spacers from the shafts.
10. Install the gear spacers (P/N 100430) on the shafts.
11. Install the rear bearing seals (P/N 100431) in the gearcase.
12. Install the timing gear keys in the shafts.
13. Align and install the timing gears on the shafts.
14. Install the lockwashers and locknuts on the shaft and torque the nuts to 600 ft-lbs. Lock in place by bending a tab on the lockwasher, using a hammer and drift punch

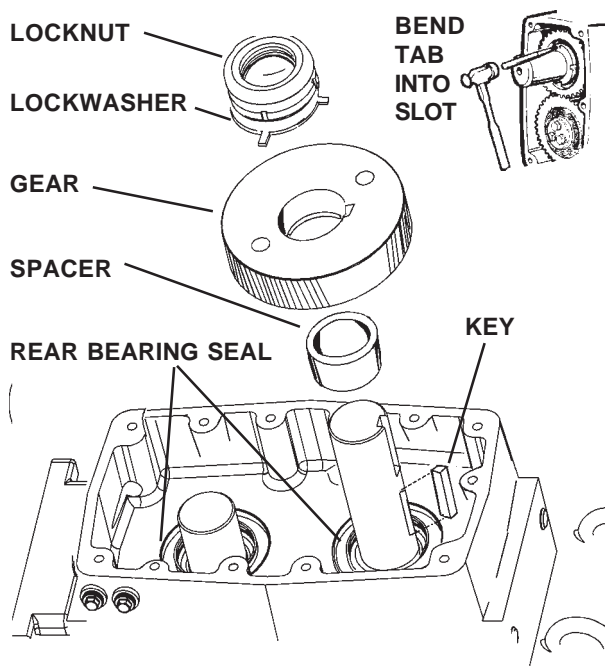

15. Install a new gearcase cover seal (P/N 100531) in the timing gear cover.
16. Apply silicone sealant to the gearcase (be sure to seal the areas around all of the tapped cover bolt holes.) and install the timing gear cover.
17. Refill timing gear housing with Micro-Plate gear lubricant and grease all bearings with Micro-Plate bearing grease.

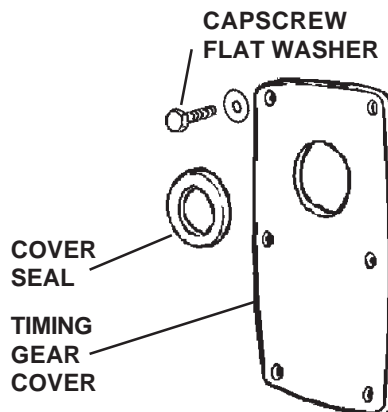

MAINTENANCE

GEARCASE ASSEMBLY ADJUSTING ROTOR TO BODY BACKFACE CLEARANCE.

If the shafts and bearings or just the shafts were replaced, in all probability, the fluid head will probably need to be reshimmed to achieve the proper rotor to body backface clearance. The Model 420 and 520 pumps are designed to accomplish this without removing the shafts from the gearcase. All fluid head shimming is done between the fluid head (body) and the fluid head mounting plate as described in the following procedure.

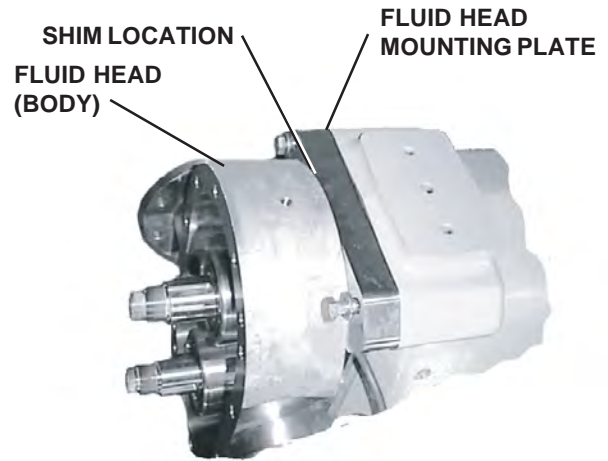

1. Install the pump fluid head on the gearcase. Make sure that all mating surfaces between the fluid head mounting plate and the gearcase mounting surface are clean and free of all burrs. The shaft seals need not be installed for this operation, and it is much simpler if they are not.
2. Measure the height difference between the rotor seat surface on the shaft and the end of the body shaft hub. The rotor seat surface on the shaft should protrude above the hub by $.009" \pm .001"$. Measure both of the shafts and record each.
3. If the measurement differs from the dimension stated in step 2 shims will have to be added or removed from between the fluid head and the fluid head mounting plate. If the measurement is OK, then go to step 8.
4. Remove the fluid head from the gearcase.
5. Remove the four retaining bolts from each fluid head mounting plate. One at a time, remove each mounting plate and add or subtract shims (P/N 100472-100476) until the desired height is reached. (Example: If step 2 yielded a measurement of $.005"$, then $.004"$ of shim would need to be added to the existing shim stack.)
6. Reinstall the fluid head mounting plates over the new shim stack and secure with the socket head retaining bolts. Torque the bolts to 70 ft-lbs.
7. Repeat steps 1,2 and 3 above.
8. Remove the fluid head from the gearcase.



MEASURE DISTANCE BETWEEN HUB SHAFT SHOULDER AND ROTOR SHOULDER

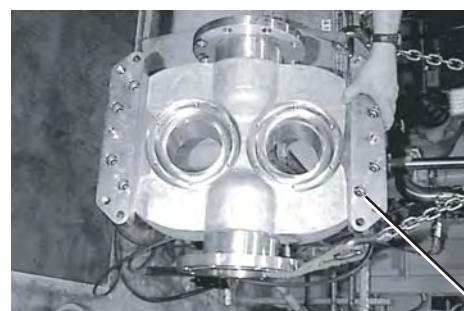
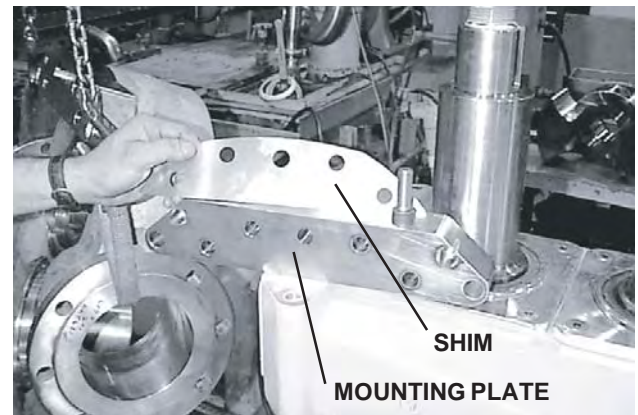

TIGHTEN BODY PLATE BOLTS TO 70 FT LBS

Refer to the section on fluid head assembly for the complete the reassembly process.

MAINTENANCE

FLUID HEAD ASSEMBLY

WAUKESHA MECHANICAL SEAL INSTALLATION

DOUBLE SEAL

- Slide shield/slinger on shaft.
- Slide the outer seal assembly onto the shaft
Care must be taken when assembling the outer seal into the outer seal retainer. All compression springs must be fully seated in the retainer. The drive notches in the outer seal must be properly aligned with the seal drive pins in the outer seal retainer.
- The leading edge of the outer seal should be .610-inches from the shaft shoulder. Fasten seal in place by tightening the two setscrews.
- Install the gland plate.
- Install the gaskets on both sides of the T-seat. Lubricate the faces on the T-seat with a food grade lubricant or other approved fluid and install the T-seat.
- The inner seal may be assembled prior to installing on shaft. Care should be taken to make sure that all springs are properly seated and that the seal face drive pins are properly aligned with the notches in the inner seal face.
Use food grade lubricants on all O-rings during seal assembly to enhance performance.
- Install the inner seal.
- Slip the inner seal preload tool over the end of the shaft. Install the rotor retaining nut, and hand tighten it against the preload tool and shaft shoulder.
- *Tighten the setscrews in the inner seal seat retainer.
- Remove the rotor retaining nut and preload tool.

*REPLACE SETSCREWS EACH TIME THE SEAL IS REMOVED FROM THE SHAFT.

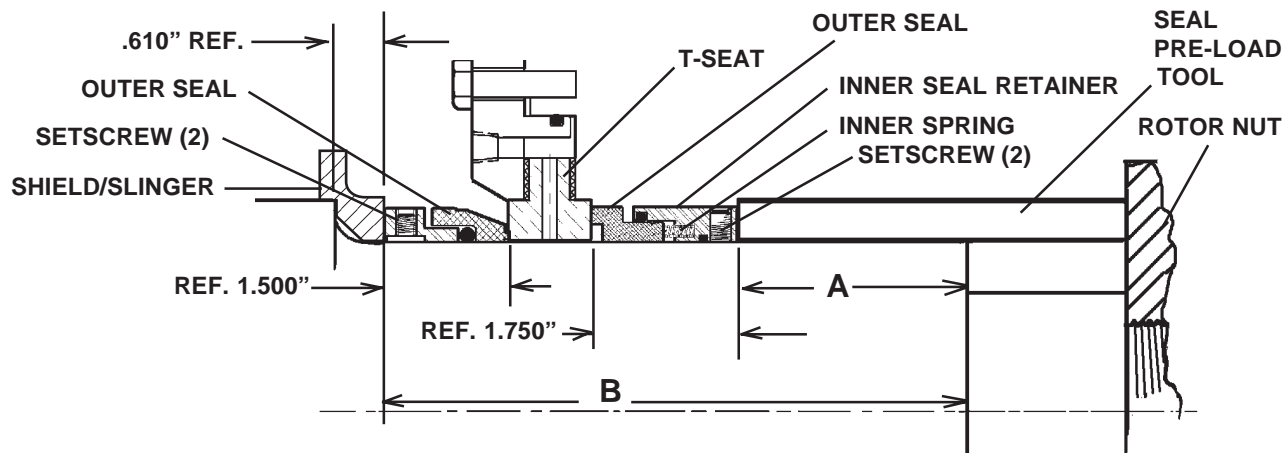

MECHANICAL SEAL DIMENSIONS

| PUMP MODEL | A | B |
|------------|--------|--------|
| 420 | 2.898" | 7.148" |
| 520 | 4.773" | 9.023" |

MAINTENANCE

FLUID HEAD ASSEMBLY

BODY INSTALLATION

The installation of the body is the reverse of the removal procedure (page 22 with the following suggestions:

1. Use the guide bolts to align the body with the gearcase. This is very helpful in preventing damage to the mechanical seals.
2. After body is fully installed, connect the seal flush lines and test for leaks by opening flush lines and establishing a flow thru the seal

NOTE Omit step 2 if unit has a single mechanical seal

ROTOR KEYS



ROTOR INSTALLATION

The installation of the rotors is the reverse of the removal procedure (page 21) with the following suggestions:

1. Replace all rotor and rotor nut O-rings with new ones.
2. The rotor drive keys may be installed after the rotor is fully seated against the shaft shoulder and the shaft extension tool has been removed.
3. USE LIBERAL AMOUNTS OF FOOD GRADE ANTI-SEIZE COMPOUND ON ROTOR RETAINING NUT AND ENCAPSULATED JAM NUT THREADS. IF NUTS DO NOT ROTATE FREELY, BY HAND, ON SHAFT THREADS, REMOVE THEM AND CLEAN OR REPAIR THREADS.
4. Rotor nuts are to be tightened to 600 foot-pounds using the torque wrench and socket.
5. Check for proper rotor to cover clearance. Minimum is .010"

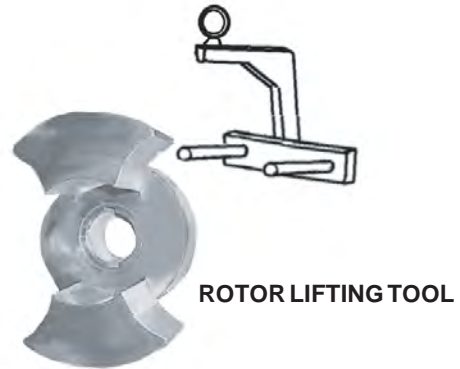

ROTOR LIFTING TOOL

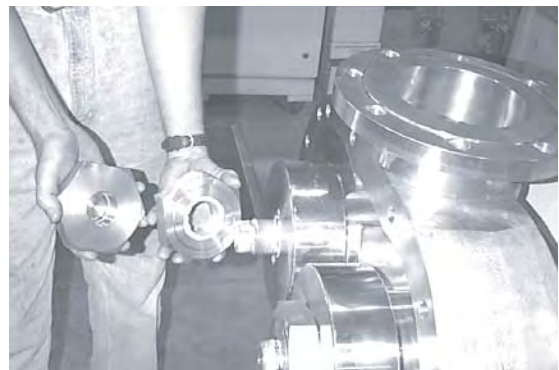

INSTALL NUTS TO 600 FT.LBS TORQUE

COVER INSTALLATION

The installation of the cover is the reverse of the removal procedure with the following suggestions:

1. Lubricate the cover O-ring.
2. Use anti-seize compound on all cover bolt threads.

COVER INSTALLATION

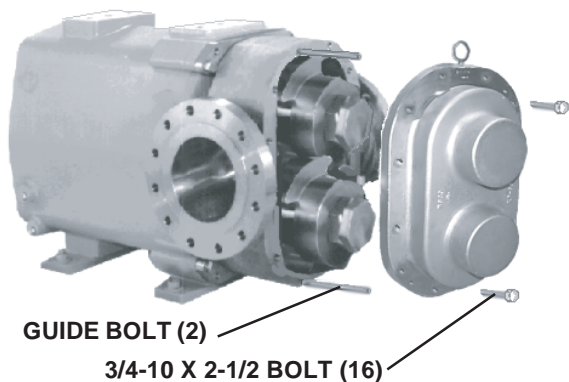

GUIDE BOLT (2)

3/4-10 X 2-1/2 BOLT (16)

UNIVERSAL MODEL 420

ITEM 34
**SINGLE AND DOUBLE
 MECHANICAL SEALS**
 (See pages 36-38)

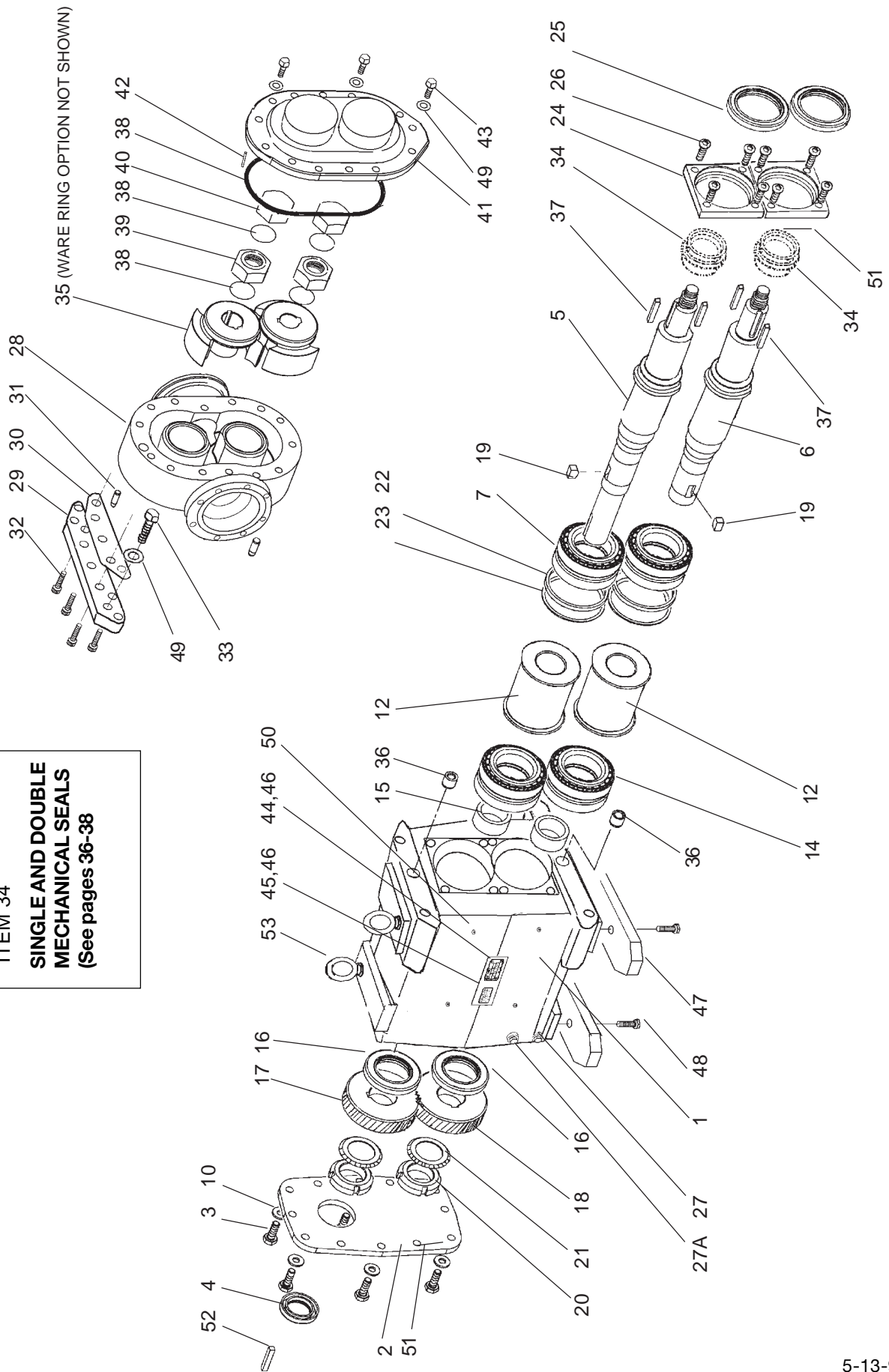

| ITEM | DESCRIPTION | PART NUMBER | QTY | ITEM | DESCRIPTION | PART NO. | QTY |
|------|-------------------------------|-------------|-----|------|---|------------------|-----|
| 1 | 420 GEARCASE SUBASSEMBLY | 100401 | 1 | 31 | DOWEL PIN, BODY | 100477 | 2 |
| 2 | GEARCASE | 100336 | 1 | 32 | SOCKET HEAD CAP SCREW 18 -8 | 30-228X | 8 |
| 3 | GEARCASE COVER | 100530 | 1 | 33 | HEX HEAD CAP SCREW 18-8-SST | 30-502 | 4 |
| 4 | 3/8-16x1 HEX HEAD CAP SCREW | 30-30 | 12 | 34 | SEAL OPTION | (SEE PAGE 36-38) | 2 |
| 4 | SEAL, GEARCASE COVER | 100531 | 1 | 35 | ROTOR OPTIONS | (SEE CHART) | 2 |
| 4 | INPUT SHAFT ISOLATOR | X08772 | 1 | 36 | BUSHING, DOWEL PIN 304-SST | 100334 | 2 |
| 5 | SHAFT, DRIVE | 100532 | 1 | 37 | ROTOR DRIVE KEY 316-SST | 100481 | 4 |
| 6 | SHAFT, SHORT | 100424 | 1 | 38 | O-RING GROUP OPTION BUNA (SEE PAGE 36-38) | 100482 | 4 |
| 7 | BEARING, FRONT | 100425 | 2 | 39 | INNER ROTOR NUT 316 | 100482 | 2 |
| 10 | FLATWASHER 3/8 | 43-189 | 12 | 40 | OUTER ROTOR NUT WM-88 | 101712 | 2 |
| 12 | SPACER, BEARING | 108378 | 2 | 41 | COVER STANDARD 316 SS | 100479 | 1 |
| 14 | BEARING, REAR | 100429 | 2 | 42 | COVER DOWEL PIN SS | 100470 | 1 |
| 15 | SPACER, GEAR | 100430 | 2 | 43 | HEX HEAD BOLT - 18-8 SST | 30-444 | 12 |
| 16 | SEAL, OUTER, REAR BEARING | 100431 | 2 | 44 | NAMEPLATE | 001 061 002 | 1 |
| 17 | GEAR, TIMING, DRIVE SHAFT | 107659 | 2 | 45 | CAUTION PLATE | 33-22 | 1 |
| 18 | GEAR, TIMING, SHORT SHAFT | 107659 | 2 | 46 | DRIVE SCREW SST | 30-355 | 12 |
| 19 | KEY, 1X1x2.5" Lg | 100434 | 2 | 47 | MOUNTING FOOT (SHIM) STEEL | 100469 | 2 |
| 20 | LOCKNUT, BEARING AN-22 | STD 236 022 | 2 | 48 | HEX HEAD BOLT 18-8 SST | 30-383 | 4 |
| 21 | LOCKWASHER, BEARING W-22 | STD 136 022 | 2 | 49 | WASHER, FLAT SST | 43-55 | 16 |
| 22 | SEAT, FRONT BEARING | 100435 | 2 | 50 | GREASE FITTING | BD0 092 000 | 8 |
| 23 | SHIM; FRONT BEARING .002" | 100436 | AR | 51 | SILICONE SEALANT, RTV | 000 142 300 | AR |
| | SHIM; FRONT BEARING .003" | 100437 | AR | 52 | DRIVE KEY | | 1 |
| | SHIM; FRONT BEARING .005" | 100438 | AR | 53 | EYEBOLT | | |
| | SHIM; FRONT BEARING .010" | 100439 | AR | XX | INSERT, WEAR, 420/52 | 21349 | 2 |
| | SHIM; FRONT BEARING .020" | 100440 | AR | XX | FHSCS, 5/16-18 X 1.00" | 30-612 | 2 |
| 24 | *RETAINER, FRONT BEARING | 114820 | 2 | | | | |
| 24 | RETAINER, FRONT BEARING | | | | | | |
| | FOR USE WITH BEARING ISOLATOR | 122679 | 2 | | | | |
| 25 | SEAL, FRONT BEARING RETAINER | 100442 | 2 | | | | |
| 25 | BEARING ISOLATOR | X08770 | 2 | | | | |
| 26 | 1/2-13x1 HEX SOC FLAT HEAD | 30-478 | 8 | | | | |
| 27 | PLUG, OIL | 115798 | 3 | | | | |
| 27A | LEVEL INDICATOR | 115799 | 1 | | | | |
| 28 | BODY-FLUID HEAD 150 LB FLANGE | 100478 | 1 | | | | |
| | BODY-FLUID HEAD 300 LB FLANGE | 101401 | 1 | | | | |
| 29 | MOUNTING PLATE 316-SST | 100471 | 2 | | | | |
| 30 | BODY SHIMS 316 .002" | 100472 | AR | | | | |
| | BODY SHIMS 316 .003" | 100473 | AR | | | | |
| | BODY SHIMS 316 .005" | 100474 | AR | | | | |
| | BODY SHIMS 316 .010" | 100475 | AR | | | | |
| | BODY SHIMS 316 .020" | 100476 | AR | | | | |

ROTOR OPTIONS CHART*

| PART NO. | CLEARANCE | MATERIAL |
|----------|-----------|----------|
| 100523 | STANDARD | WM 88 |
| 101427 | FF | WM 88 |
| 101430 | HOT | WM 88 |
| 101434 | STANDARD | 316L-SST |
| 101437 | FF | 316L-SST |
| 101440 | HOT | 316L-SST |

*CONSULT FACTORY FOR OTHER OPTIONS

.AR= AS REQUIRED

UNIVERSAL MODEL 420

UNIVERSAL MODEL 520

ITEM 34
**SINGLE AND DOUBLE
 MECHANICAL SEALS**
 (See pages 36-38)

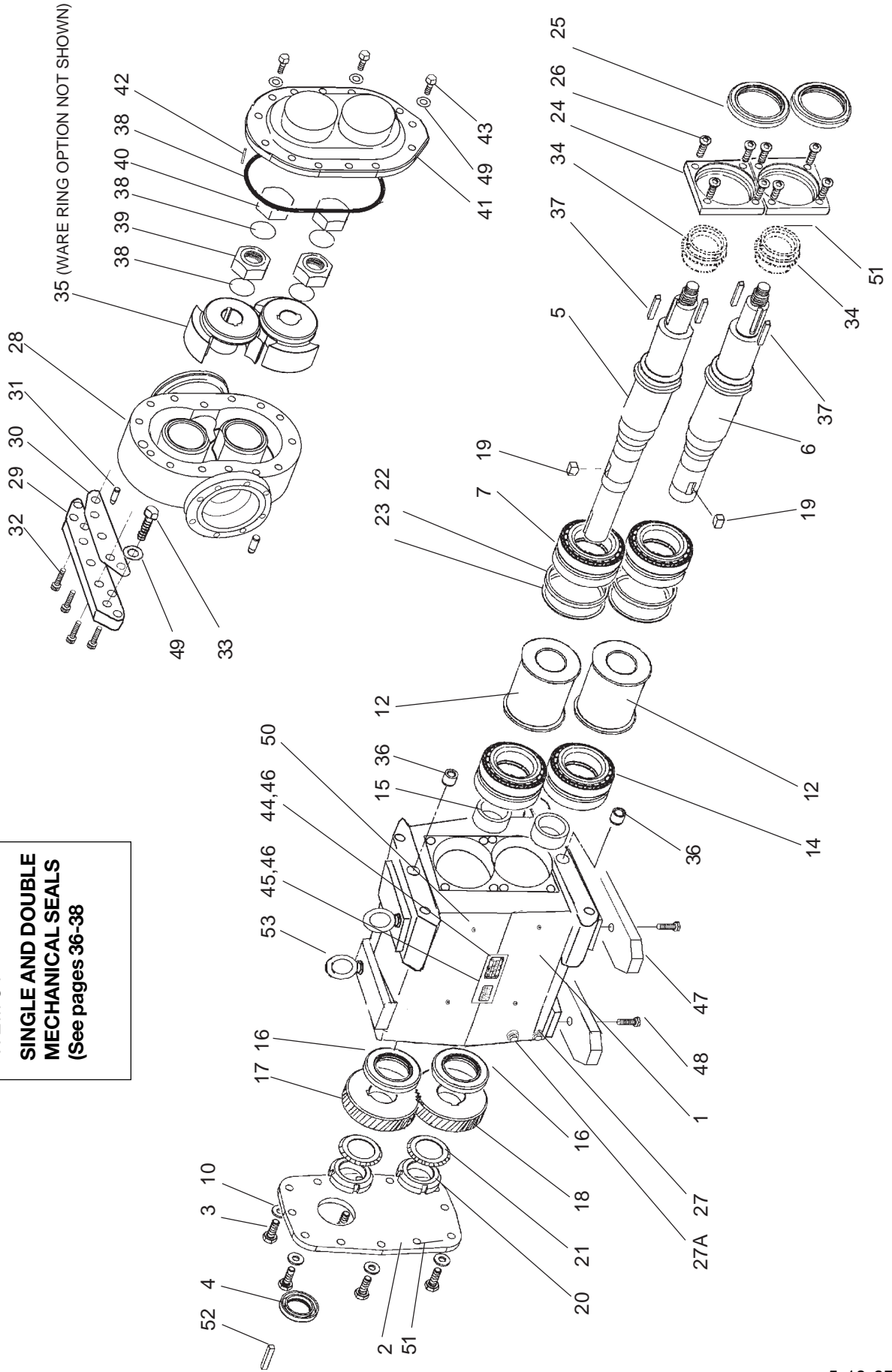

| ITEM | DESCRIPTION | PART NUMBER | QTY | ITEM | DESCRIPTION | PART NO. | QTY |
|------|-------------------------------|-------------|-----|------|---|------------------|-----|
| 520 | GEARCASE SUBASSEMBLY | 100401 | 1 | 31 | DOWEL PIN, BODY | 100477 | 2 |
| 1 | GEARCASE | 100336 | 1 | 32 | SOCKET HEAD CAP SCREW 18 - 8 | 30-228X | 8 |
| 2 | GEARCASE COVER | 100530 | 1 | 33 | HEX HEAD CAP SCREW 18-8-SST | 30-502 | 4 |
| 3 | 3/8-16x1 HEX HEAD CAP SCREW | 30-30 | 12 | 34 | SEAL OPTION | (SEE PAGE 36-38) | 2 |
| 4 | SEAL, GEARCASE COVER | 100531 | 1 | 35 | ROTOR OPTIONS | (SEE CHART) | 2 |
| 4 | INPUT SHAFT ISOLATOR | X08772 | 1 | 36 | BUSHING, DOWEL PIN 304-SST | 100334 | 2 |
| 5 | SHAFT, DRIVE | 100673 | 1 | 37 | ROTOR DRIVE KEY 316-SST | 100481 | 2 |
| 6 | SHAFT, SHORT | 100675 | 1 | 38 | O-RING GROUP OPTION BUNA (SEE PAGE 36-38) | 100482 | 4 |
| 7 | BEARING, FRONT | 100425 | 2 | 39 | INNER ROTOR NUT 316 | 101712 | 2 |
| 10 | FLATWASHER 3/8 | 43-189 | 12 | 40 | OUTER ROTOR NUT WM-88 | 100479 | 1 |
| 12 | SPACER, BEARING | 108378 | 2 | 41 | COVER STANDARD 316 SS | 100470 | 1 |
| 14 | BEARING, REAR | 100429 | 2 | 42 | COVER DOWEL PIN SS | 30-444 | 12 |
| 15 | SPACER, GEAR | 100430 | 2 | 43 | HEX HEAD BOLT - 18-8 SST | 001 061 002 | 1 |
| 16 | SEAL, OUTER, REAR BEARING | 100431 | 2 | 44 | CAUTION PLATE | 33-22 | 1 |
| 17 | GEAR, TIMING, DRIVE SHAFT | 107659 | 2 | 45 | DRIVE SCREW SST | 30-355 | 12 |
| 18 | GEAR, TIMING, SHORT SHAFT | 107659 | 2 | 46 | MOUNTING FOOT (SHIM) STEEL | 100469 | 2 |
| 19 | KEY, 1x1x2.5" Lg | 100434 | 2 | 47 | HEX HEAD BOLT 18-8 SST | 30-383 | 4 |
| 20 | LOCKNUT, BEARING AN-22 | STD 236 022 | 2 | 48 | WASHER, FLAT SST | 43-55 | 16 |
| 21 | LOCKWASHER, BEARINGW-22 | STD 136 022 | 2 | 49 | GREASE FITTING | BD0 092 000 | 8 |
| 22 | SEAT, FRONT BEARING | 100435 | 2 | 50 | SILICONE SEALANT, RTV | 000 142 300 | AR |
| 23 | SHIM, FRONT BEARING .002" | 100436 | AR | 51 | DRIVE KEY | | 1 |
| | SHIM, FRONT BEARING .003" | 100437 | AR | 52 | EYEBOLT | | 1 |
| | SHIM, FRONT BEARING .005" | 100438 | AR | 53 | INSERT, WEAR 420/520 | 21349 | 8 |
| | SHIM, FRONT BEARING .010" | 100439 | AR | XX | FHSCS, 5/16-18"X1.0" | 30-612 | AR |
| | SHIM, FRONT BEARING .020" | 100440 | AR | XX | | | AR |
| 24 | RETAINER, FRONT BEARING | 114820 | 2 | | | | |
| 24 | RETAINER FRONT BEARING | | | | | | |
| | FOR USE WITH BEARING ISOLATOR | 122679 | 2 | | | | |
| 25 | SEAL, FRONT BEARING RETAINER | 100442 | 2 | | | | |
| 25 | BEARING ISOLATOR | X08770 | 2 | | | | |
| 26 | 1/2-13x1 HEX SOC FLAT HEAD | 30-478 | 8 | | | | |
| 27 | PLUG, OIL | 115798 | 3 | | | | |
| 27A | LEVEL INDICATOR | 115799 | 1 | | | | |
| 28 | BODY-FLUID HEAD 150 LB FLANGE | 101404 | 1 | | | | |
| | BODY-FLUID HEAD 300 LB FLANGE | 100677 | 1 | | | | |
| 29 | MOUNTING PLATE 316-SST | 100471 | 2 | | | | |
| 30 | BODY SHIMS 316 .002" | 100472 | AR | | | | |
| | BODY SHIMS 316 .003" | 100473 | AR | | | | |
| | BODY SHIMS 316 .005" | 100474 | AR | | | | |
| | BODY SHIMS 316 .010" | 100475 | AR | | | | |
| | BODY SHIMS 316 .020" | 100476 | AR | | | | |

ROTOR OPTIONS CHART*

| PART NO. | CLEARANCE | MATERIAL |
|----------|-----------|----------|
| 100683 | STANDARD | WM 88 |
| 102358 | FF | WM 88 |
| 102371 | HOT | WM 88 |
| 102375 | STANDARD | 316L-SST |
| 102371 | FF | 316L-SST |
| 102381 | HOT | 316L-SST |

*CONSULT FACTORY FOR OTHER OPTIONS.

.AR= AS REQUIRED

UNIVERSAL MODEL 520

DOUBLE MECHANICAL SEAL

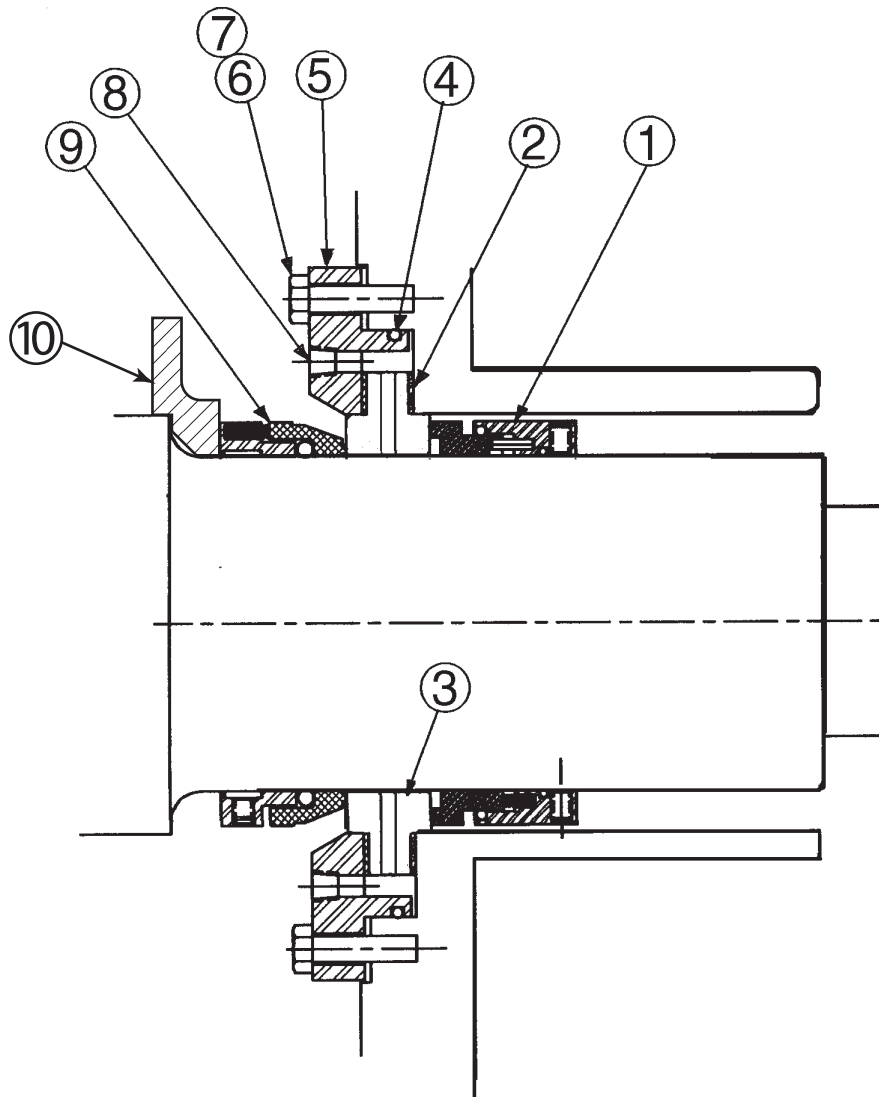

DOUBLE MECHANICAL SEAL

| ITEM | DESCRIPTION | PART NUMBER | | | | | | |
|------|-----------------|------------------------|-----------------------|-----------------------|------------------------|------------------------|------------------------|-----------------------|
| | | *100402 SC/SC-C/SCS | 102516 SC/SC-C/SCV | 102517 SC/SC-C/SCE | 102518 SC/SC-TN/SCS | 102519 SC/SC-TN/SCV | 102520 SC/SC-TN/SCE | 107000 SC/SC-C/SCE |
| 1 | INBOARD SEAL | 10515 | 102503 | 102504 | 100512 | 102503 | 102504 | 102504 |
| 2 | GASKET | 10512 | 102524 | 102525 | 100515 | 102524 | 102525 | 107001 |
| 3 | SEAT | 420-014-031 | 420-014-031 | 420-014-031 | 420-014-031 | 420-014-031 | 420-014-031 | 420-014-031 |
| 4 | O-RING | S75260 | V70260 | E70260 | S75260 | V70260 | E70260 | E70260 |
| 5 | GLAND | 100514 | 100514 | 100514 | 100514 | 100514 | 100514 | 100514 |
| 6 | 5/16-18X1¼ HHCS | 30-353 | 30-353 | 30-363 | 30-353 | 30-353 | 30-353 | 30-353 |
| 7 | 5/16 LOCKWASHER | 43-15 | 43-15 | 43-15 | 43-15 | 43-15 | 43-15 | 43-15 |
| 8 | FLUSH KIT | 35897 | 35897 | 35897 | 35897 | 35897 | 35897 | 35897 |
| 9 | OUTBOARD SEAL | 100513 | 102508 | 102509 | 102513 | 102514 | 102515 | 102509 |
| 10 | SHIELD/SLINGER | 114035 | 114035 | 114035 | 114035 | 114035 | 114035 | 114055 |

*WAUKESHA HEAVY DUTY STANDARD SEAL

SINGLE INNER MECHANICAL SEAL

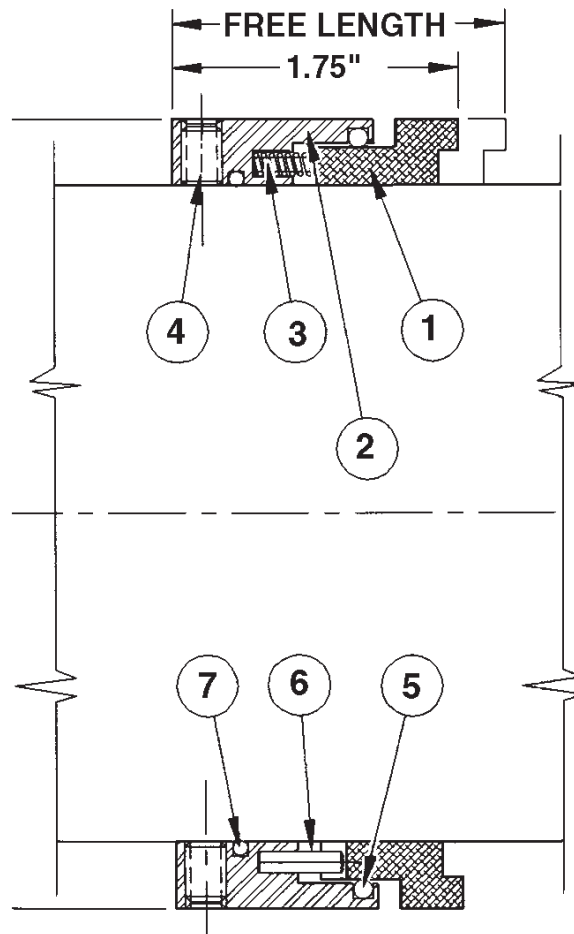

420 - 520 INNER SEAL ASSEMBLY 102150 *AS SUPPLIED BY VENDOR

| ITEM | REQ'D | PART NUMBER | DESCRIPTION |
|------|-------|-------------|------------------------------|
| *1 | 1 | 102526 | FACE, SILICONE/CARBIDE ROTOR |
| *2 | 1 | 102527 | RETAINER |
| *3 | 24 | 102528 | SPRING |
| *4 | 4 | 102529 | SETSCREW |
| 5 | 1 | SEE TABLE | RETAINER O-RING |
| *6 | 3 | WITH ITEM 2 | DRIVE PIN |
| 7 | 1 | SEE TABLE | SHAFT O-RING |

SINGLE MECHANICAL SEAL ASSEMBLIES TYPE "MP" (INNER)

| ROTATING FACE | O-RING MATERIAL | SEAL ASSEMBLY WITH O-RINGS |
|---------------|-----------------|----------------------------|
| SILICONE | SILICONE | 102512 |
| CARBIDE | FLUOROELASTOMER | 102503 |
| | EDP | 102504 |

| O-RING | ITEM 5 | ITEM 7 | MATERIAL |
|--------|--------|--------|-----------------|
| | S70246 | S70242 | SILICONE RUBBER |
| | V70246 | V70242 | FLUOROELASTOMER |
| | E70246 | E70242 | EDP |

SINGLE OUTER MECHANICAL SEAL

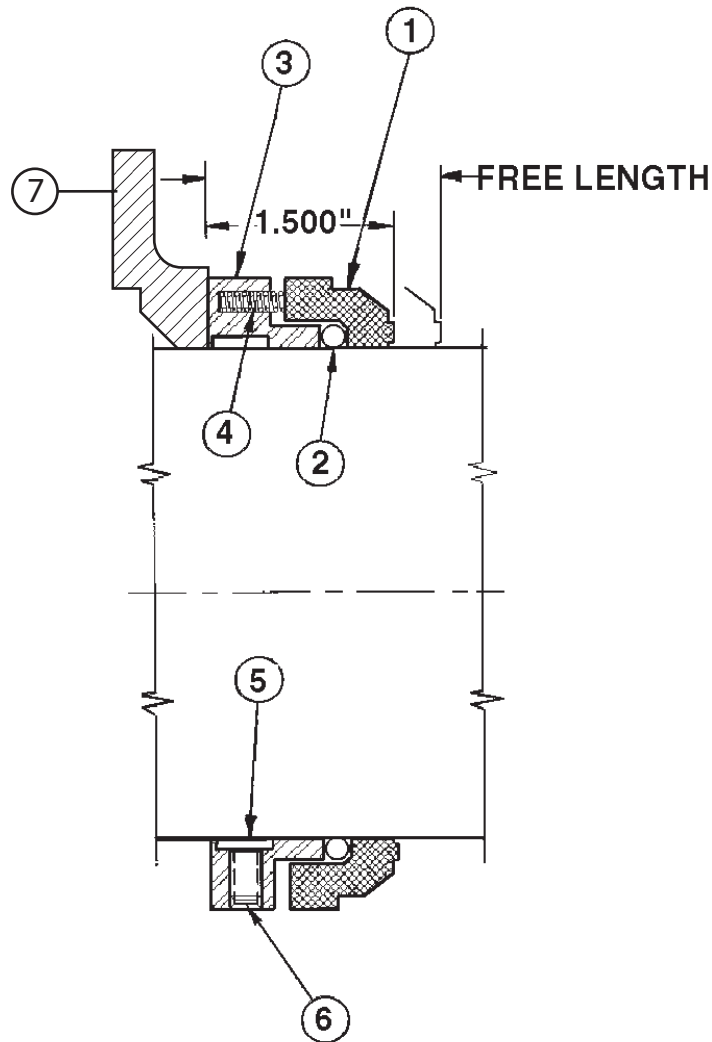

420 - 520 INNER SEAL ASSEMBLY 102138 *AS SUPPLIED BY VENDOR

| ITEM | REQ'D | PART NUMBER | DESCRIPTION |
|------|-------|-------------|--------------------|
| *1 | 1 | 102659 | FACE, CARBON ROTOR |
| 2 | 1 | SEE TABLE | O-RING |
| *3 | 1 | 102661 | RETAINER |
| *4 | 9 | 102693 | SPRING |
| *5 | 1 | 102552 | SPLIT RING |
| *6 | 34 | 102663 | SETSCREW |
| 7 | 1 | 114035 | SHIELD/SLINGER |

SINGLE MECHANICAL SEAL ASSEMBLIES TYPE "CO" (OUTER)

| ROTATING FACE | O-RING MATERIAL | O-RING | SEAL ASSEMBLY WITH O-RING |
|---------------|-----------------|--------|---------------------------|
| CARBON | SILICONE | S75345 | 102513 |
| | FLUOROELASTOMER | V70345 | 102514 |
| | EDP | E70345 | 105515 |

PARTS ORDERING

Any correspondence concerning valves will require the following information be documented:

PRODUCT NAME/MODEL: _____

PRODUCT SERIAL NUMBER: _____

DATE OF PURCHASE: _____

INVOICE NUMBER: _____

INVOICE DATE: _____

HOW TO ORDER PARTS

By Phone

Telephone your repair parts or fittings order to your Distributor.

To speed your order and avoid delays, please have your **equipment model** and **serial number** and the **part numbers** from the parts list before you call your Distributor.

If you do not know your Distributors number, call Waukesha Cherry-Burrell Customer Service at:

Phone: **800-252-5200** or 262-728-1900

Fax: **800-252-5012** or 262-728-4904

Your call will be directed to a specialist who can provide you with Distributor information for your area.

How to Return Parts

Parts may be returned for credit, subject to the conditions of our return goods policy. To obtain authorization to return a part, contact the your Distributor.

Please give the following information:

Invoice number and date

Quantity

Part Number (from parts list)

Exact reason for return

Your Distributor will provide a Return Goods Authorization. (Returns will not be accepted without advance authorization.)

DISTRIBUTOR: _____

ADDRESS: _____

CITY: _____ STATE: _____ ZIP: _____

CONTACT: _____

PHONE: _____

FAX: _____

NOTES

Aseptic/Steam Purge Models

Flushing Connection

Aseptic pumps may be installed for horizontal or vertical product flow.

The flanged ports and cover both have extra flush connection ports located to optimize the flow when used in either position.

The unused flush ports must be plugged before placing the pump and flush system in service.

| | |
|---|--|
|  | <p>NOTE: Flushing media may be piped into either side for both shaft seals and discharged to drain on opposite side. Both inlets may be manifolded to simplify piping. Be sure flush water is flowing out both discharge lines. Piping for steam should be determined in accordance with local codes.</p> |
|---|--|

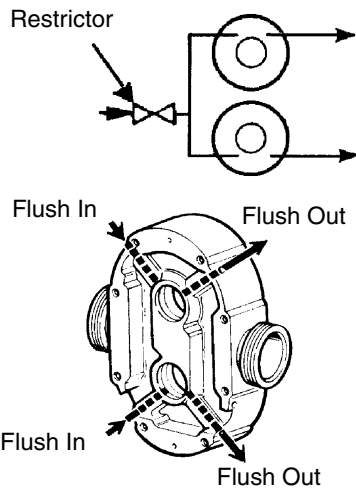

Low Pressure Flush

1. Set a flow rate of approximately 1/4 GPM for most applications. For high temperature applications, increase the flow. The flowrate supplied must be adequate to purge the system.
2. Flushing media is restricted on the inlet side and has free flow to drain on the outlet side.
3. Typical flushing connections are 1/8" NPT female pipe taps.

Flushing Connection - "Aseptic Series"

All connections are 1/8" female pipe taps. The pump has double "barriers" or seals at every opening to the pump chamber. Live steam or a sterile fluid is circulated between these double seals at the ports, in the cover and at the shaft seals.

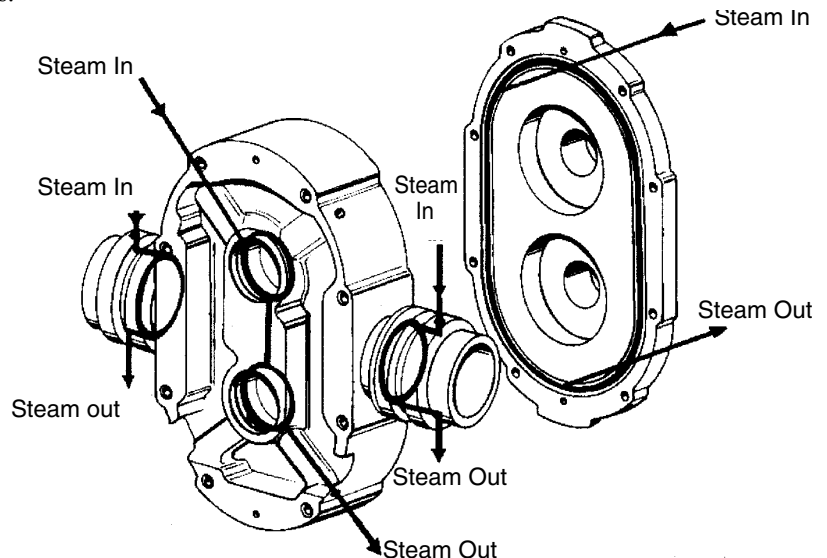

Aseptic Cover

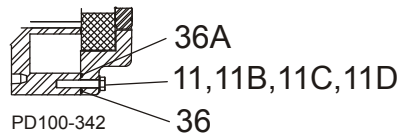

Aseptic Flange

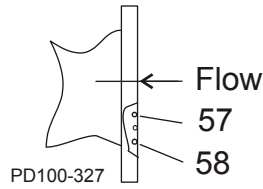

| ITEM NO. | DESCRIPTION | QTY. PER PUMP | PART NO. | NOTES |
|----------------------------------|--|---------------|----------|-------|
| 11 | 3/4-10 x 2-1/2" HHCS | 12 | 30-444 | |
| 11B | 420-520-UHC Flat Washer, 3/4" | 12 | 43-55 | |
| | 423-523-UHC Sealing Washer, 3/4" | 12 | 43-204 | 11 |
| 11C | 1/2-13 x 5/8" HHCS | 2 | 30-497 | 11 |
| 11D | 423-523-UHC Sealing Washer, 1/2" | 2 | 43-203 | 11 |
| * * * * 36 | O-Ring, Pump Cover, Buna N | 1 | N70387 | |
| | O-Ring, Pump Cover, EPDM | 1 | E70387 | |
| | O-Ring, Pump Cover, FKM | 1 | V70387 | |
| | O-Ring, Pump Cover, Silicone | 1 | S75387 | |
| 36A | 423-523-UHC O-Ring, Pump Cover, Silicone | 1 | 102666 | 11 |
| * * * * * * 57 | 423-UHC O-Ring, Port, Inner, Silicone | 2 | S75261 | 11 |
| | 423-UHC O-Ring, Port, Inner, EPDM | 2 | E70261 | 11 |
| | 423-UHC O-Ring, Port, Inner, FKM | 2 | V70261 | 11 |
| | 523-UHC O-Ring, Port, Inner, Silicone | 2 | S75267 | 11 |
| | 523-UHC O-Ring, Port, Inner, EPDM | 2 | E70267 | 11 |
| | 523-UHC O-Ring, Port, Inner, FKM | 2 | V70267 | 11 |
| * * * * * * 58 | 423-UHC O-Ring, Port, Inner, Silicone | 2 | S75265 | 11 |
| | 423-UHC O-Ring, Port, Outer, EPDM | 2 | E70265 | 11 |
| | 423-UHC O-Ring, Port, Outer, FKM | 2 | V70265 | 11 |
| | 523-UHC O-Ring, Port, Inner, Silicone | 2 | S75272 | 11 |
| | 523-UHC O-Ring, Port, Outer, EPDM | 2 | E70272 | 11 |
| | 523-UHC O-Ring, Port, Outer, FKM | 2 | V70272 | 11 |

PL5060-CH107a

NOTES:

11. Used on 423-523-UHC only.

* Recommended Spare Parts

SPX[®]

PROCESS EQUIPMENT

Your local contact:



THE WILLIAMS - CARVER COMPANY, INC.

4001 MISSION RD P.O. BOX #3140

KANSAS CITY, KS 66103-0140

Office (913) 236-4949 Fax (913) 236-9331

www.williamscarver.com

SPX Process Equipment
611 Sugar Creek Road
Delavan, WI 53115
Phone: (262)728-1900 or (800)252-5200 Fax: (262)728-4904 or (800)252-5012
E-mail: wcb@spx.com

For more information about our worldwide locations, approvals, certifications, and local representatives, please visit www.spxpe.com.

SPX Corporation reserves the right to incorporate our latest design and material changes without notice or obligation. Design features, materials of construction and dimensional data, as described in this bulletin, are provided for your information only and should not be relied upon unless confirmed in writing. Certified drawings are available upon request.