



Universal 420/520 High Capacity Rotary Positive Displacement Pumps



High-Volume Capacity with the Reliability of a Waukesha Cherry-Burrell

For more than half a century, Waukesha Cherry-Burrell has been a leader in the design, manufacturing and application of external circumferential, piston-type, positive displacement pumps. Waukesha PD pumps are in service around the world in food, dairy, canning, bakery, beverage and pharmaceutical processing, as well as challenging chemical and industrial applications.

Users of Waukesha PDs benefit from decades of continuing product improvement. Steady advances in design, metallurgy and fabrication techniques have yielded progressively higher levels of performance and service life. Over the years, this tradition has overcome countless pumping challenges — from high-viscosity to abrasiveness to metering accuracy.

The 420 & 520 models overcome a prodigious challenge: reliable and accurate pumping at high-volume capacities. Every revolution of the Model 420 pumps more than 1.6 gallons (6 liters) of product. Model 520, more than 2.3 gallons (8.7 liters).

Significantly, Models 420 & 520 are not just scaled up Waukesha PDs. They incorporate fresh design approaches that simplify installation, ease pump maintenance and extend pump life.

Sanitation Features

- Rotor/shaft connection sealed from product zone.
- Sideway mounting capability for better draining.
- 316 pump body and cover.
- Exclusive, non-galling Waukesha “88” alloy rotors standard; permits running at tighter clearances and higher efficiencies; 316 stainless also available.
- Mechanical seals standard.
- Aseptic model option available.

Long-life Features

- Large diameter 17-4 PH shafts for greater strength.
- Heavy duty bearing frame.
- Double tapered roller bearings contribute further to precise rotor movement and longer seal life.
- Body bolted to gearcase to maintain seal face contact, when removing cover and rotors.
- Greased lubed bearings for positive lubrication to all bearings over entire speed, temperature and pressure range.
- No bearing in product zone.
- Rotor nuts designed for extended service without loosening.



Typical product applications

Canning

Tomato ingredient
Vegetables, diced, slurries
Pet foods

Chemical/Industrial

Solvents
Fuels
Oils & Lubricants
Paper pulp slurry
Sludges

Installation/Maintenance Flexibility

- Bi-directional flow. No flow direction specification needed.
- 4-Way mounting of gear case, including vertical alignment of ports.
- Side mount gearcase mounting feet available.
- Waukesha single, double or commercially available mechanical seals.
- External shimming simplifies internal clearance adjustments.
- Upper or lower shaft position.
- Bearing lube fittings located on both sides of gearcase.
- Labyrinth or magnetic seal bearing protection available.

Performance and Long Life Through Engineering.

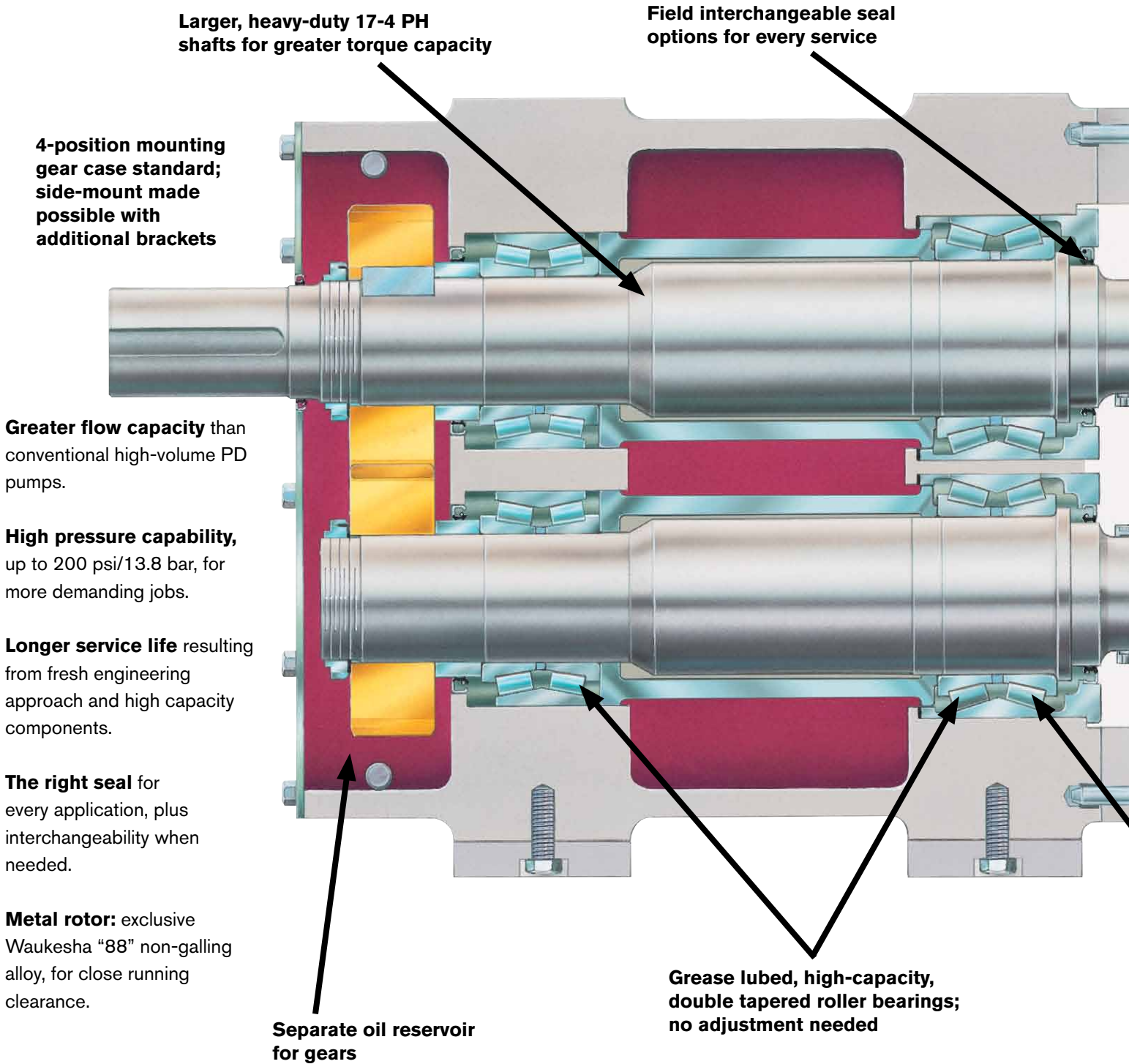

Seal Options

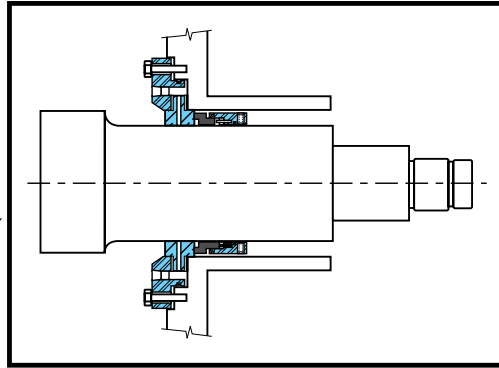
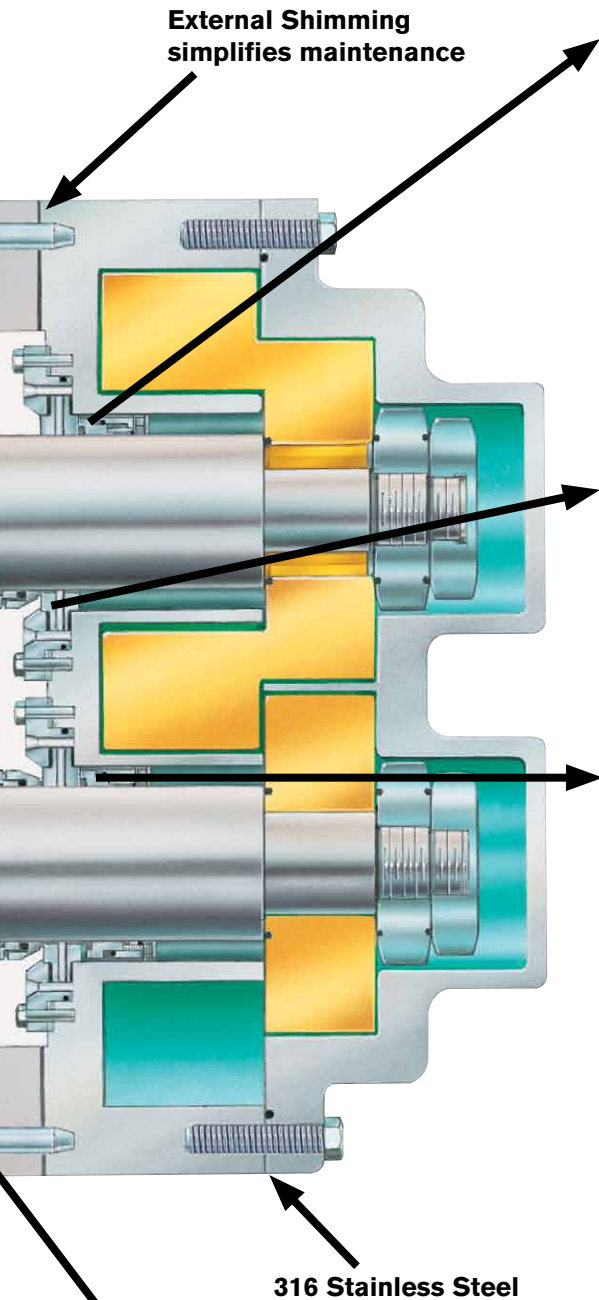

Single Inner Mechanical Seal

Silicone carbide-to-silicone carbide faces standard.

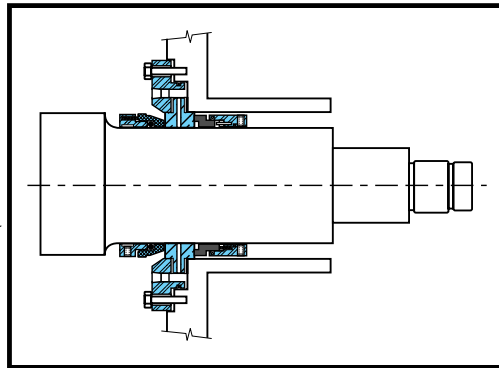

Single Outer Mechanical Seal

Carbon-to-silicone carbide faces standard.

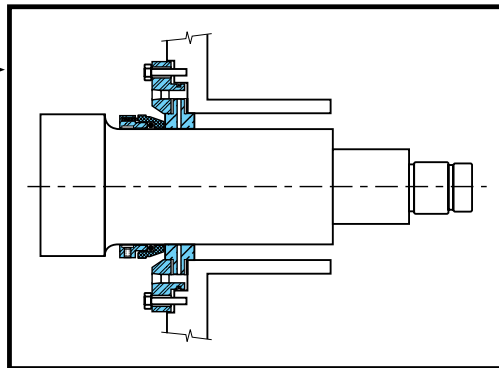

Double Mechanical Seal

Used with flushing fluid to cool, lubricate, flush away residue. Best arrangement for severe service. Combines above single inner and outer seals.

Cartridge Seal

Consult factory.

Elastomer choices for "O" rings:

- Viton
- EPDM
- Silicone

Dimensions

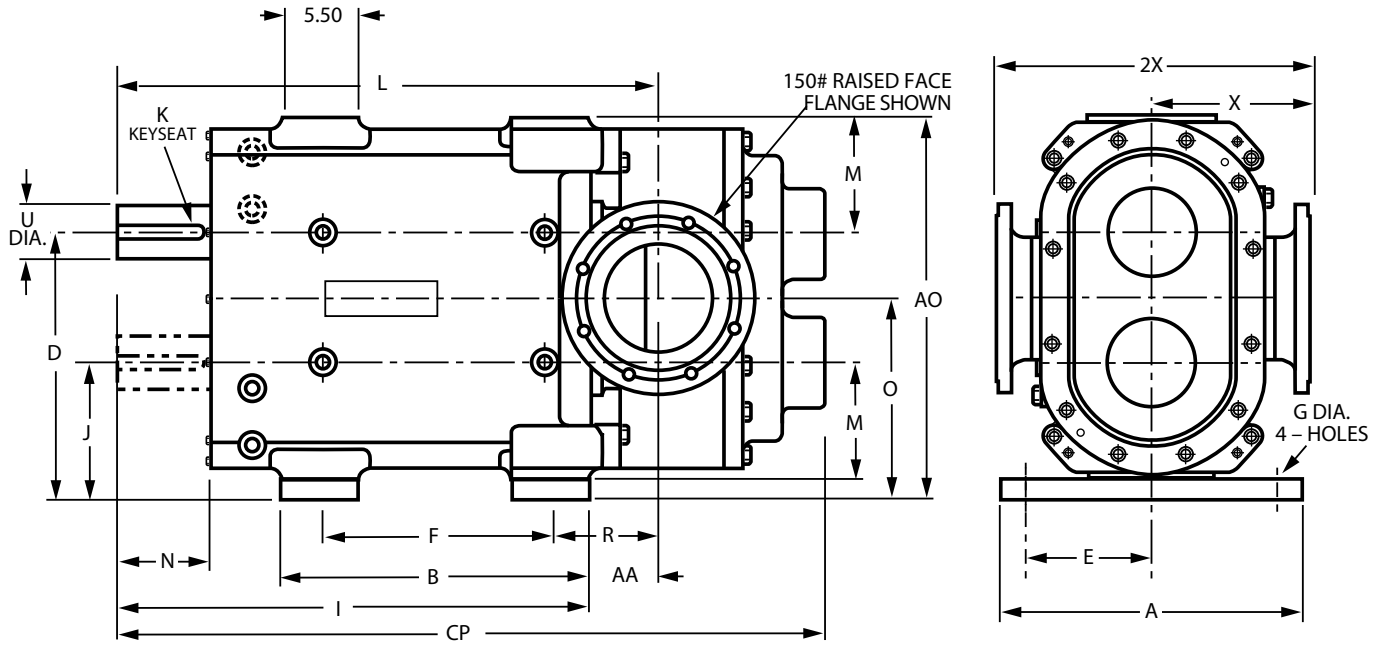

Model	IN/mm	A	AA	AO	B	CP	D	E	F	G	I	J
420-UHC	IN	21.00	5.60	27.25	22.00	49.60	18.75	9.00	16.50	1.06	33.60	9.75
423-UHC	mm	533.4	142.7	692.2	558.8	1259.8	476.2	228.6	419.1	26.92	853.4	247.6
520-UHC	IN	21.00	5.95	27.25	22.00	51.47	18.75	9.00	16.50	1.06	33.60	9.75
523-UHC	mm	533.4	151.1	692.2	558.8	1307.3	476.2	228.6	419.1	26.92	853.4	247.6
Model	IN/mm	K	L	M	N	O	R	U	X	2X	Flange Size	
420-UHC	IN	1.00	39.19	8.50	6.04	14.25	8.35	3.875	11.25	22.50	ANSI 6"	
423-UHC	mm	25.4	995.4	215.9	153.4	362	212.1	98.42	285.7	571.5		
520-UHC	IN	1.00	39.55	8.50	6.04	14.25	8.70	3.875	11.25	22.50	ANSI 8"	
523-UHC	mm	25.4	1004.6	215.9	153.4	362	221.0	98.42	285.7	571.5		

Specifications

Model	Displacement Per Revolution	Nominal Capacity To	Inlet/Outlet	Pressure Range Up To*	Maximum RPM	Temp. Range
420-UHC 423-UHC	1.619 Gal. (6.13 Liter)	648 GPM (147 m ³ /hr)	6" 150 lb. RF	200 PSI (13.8 bar)	400	-40° F/C to 300°F (149°C)
520-UHC 523-UHC	2.375 Gal. (8.99 Liter)	830 GPM (187 m ³ /hr)	8" 150 lb. RF	150 PSI (10.3 bar)	350	

*Contact application engineering for higher pressure applications.

Time-tested Waukesha Cherry-Burrell rotary pump; external circumferential piston (ECP) operating principle

In the Waukesha design, arc-shaped “pistons” (rotor wings) travel in annular-shaped cylinders machined in the pump body; the resulting long sealing path reduces slippage and produces a smooth flow of product without destructive pulses or pressure peaks and without valves or complex parts. Accurate and uniform displacement volume provides metering capabilities and good flow control.

Exclusive Waukesha Design Features

For Low Viscosity Fluids, Rotors, made of exclusive Waukesha “88” alloy, can be run with close clearance to the 316 stainless steel fluid head, without galling or seizing should inadvertent pressure surges cause contact. The close clearances combined with the rotor geometry, which gives a long sealing path between the pump inlet and outlet, means low slip operation. As a result, you achieve: high efficiency, good priming ability, metering capability and good flow control.

For High Viscosity Fluids, the large fluid cavities of the rotors ... plus the large, easy entry anti-cavitation ports ... allow efficient pumping of high viscosity fluids, slurries or even liquids with large chunks or particles.

For Non-Lubricating and Abrasive Fluids, the unique Waukesha design has no bearings in the fluid being pumped, no sliding or rolling contact and no rotor-to-rotor contact. This produces **MAXIMUM SERVICE LIFE** even under severe operating conditions.

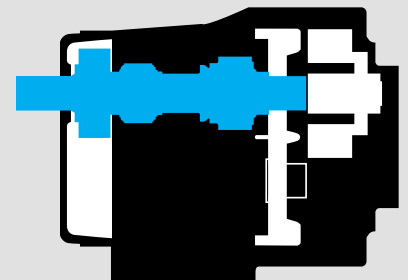
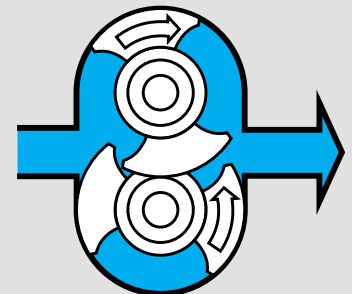
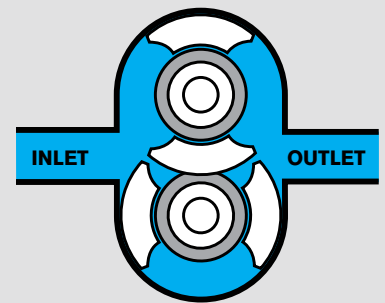
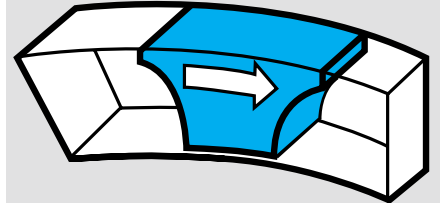

Standard Options

Ports

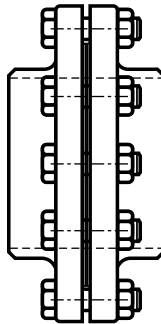

150 LB RF Flange Standard
300 LB RF Flange Available

Rotors

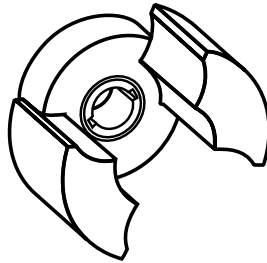

Alloy 88 Standard.
316 SS Optional.

Rotor clearance standard for most applications up to 200° F.

Hot clearance rotor option for applications up to 300° F. Other special clearances available.

O-Rings

Elastomer Choices for “O” Rings:

- Viton
- EPDM
- Silicone

Aseptic Models

Double barriers or seals protect at every opening to the pump chamber. Live steam or a sterile fluid is circulated between these double seals at the ports, in the cover and at the shaft seals form an impenetrable barrier to contaminants.

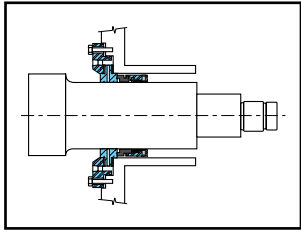

Single Mechanical Seal, Inside

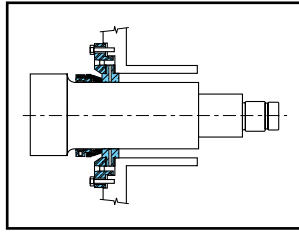

Single Mechanical Seal, Outside

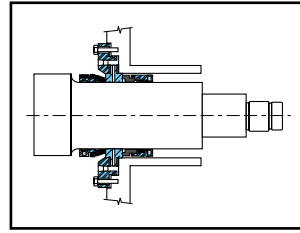

Double Mechanical Seal

Seals

Mechanical seal material options:

- Silicone Carbide
- Carbon

Consult factory for cartridge or other seal options.

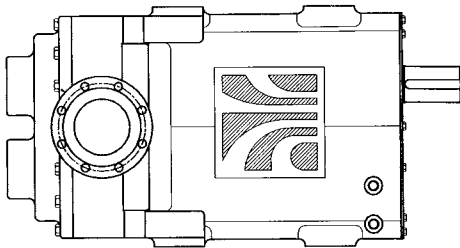

Top Shaft Position, Standard

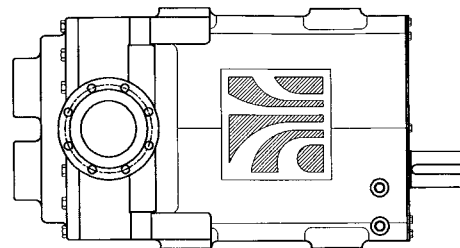

Lower Shaft Position, Optional

Shaft Position

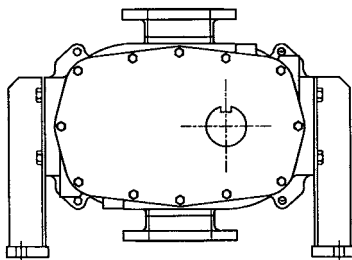

Standard Left Hand Shaft Position

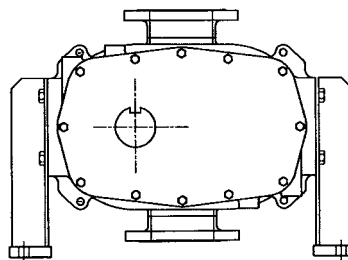

Optional Right Hand Shaft Position

Optional Mounting

Field Interchangeable

Optional Side Mount Gear Case for vertical fluid entry available.

- Fabricated or Stainless Steel Bases
- Direct connected Gear Motors
- Mechanical and Electronic Variable Speed Drives

Bases and Drives

Engineering

Research, design and application engineers at Waukesha Cherry-Burrell possess extensive backgrounds in their respective fields. You can draw on this experience to solve pumping problems or to counsel on process systems design. The imagination and resourcefulness of our engineers have often helped improve our customers' profits through production efficiencies.

Testing

Ideas do not remain abstract long at Waukesha Cherry-Burrell. Application of our products to our customer's specific needs often requires practical testing using real-world parameters. We have a fully equipped and staffed facility for this purpose. For example, the Rheology Laboratory tests applications involving highly viscous fluids.

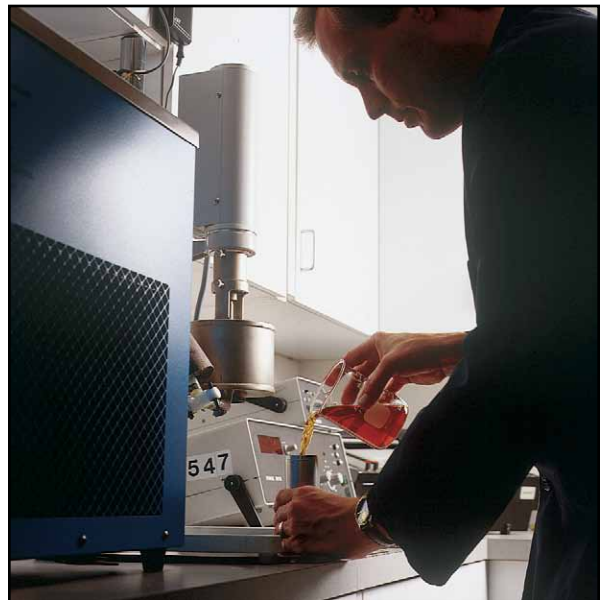

Sales & Service Network

Waukesha Cherry-Burrell's trained sales and application engineers are always available for personal consultation to help solve any installation or operational problem. A large number of fully trained Waukesha stocking distributors throughout the country and around the world provide quality Waukesha replacement parts and service.

Quality Control

To maintain the product line's reputation for quality and to assure that every unit is shipped "ready to install," each Waukesha pump is thoroughly inspected at every stage of manufacturing and assembly and then tested for design specification. Following the tests, it is disassembled and reinspected before shipment. Waukesha Cherry-Burrell has received certification of ISO 9001.

Metallurgical Control

Waukesha's reputation for pump reliability under severe operating conditions is directly related to carefully controlled casting production and consistency of metallurgical properties. It is this control that assures castings of uniform analysis that will perform dependably under all operating conditions.



Website

For technical details on products and services available from SPX Flow Technology, contact us at www.spxflowtechnology.com.

Download specific technical product information including:

- Brochures
- Data sheets
- Maintenance Manuals

Other Waukesha Cherry-Burrell Equipment:



Double Seat Valves

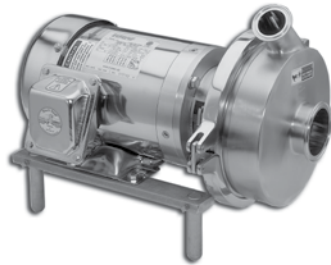

Centrifugal Pumps



Single Seat Valves



Votators®

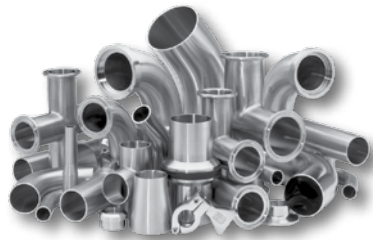

Fittings

SPX®

Your local contact:



THE WILLIAMS - CARVER COMPANY, INC.

4001 MISSION RD P.O. BOX #3140

KANSAS CITY, KS 66103-0140

Office (913) 236-4949 Fax (913) 236-9331

www.williamscarver.com



SPX Flow Technology
611 Sugar Creek Road
Delavan, WI 53115

Phone: (262)728-1900 or (800)252-5200 Fax: (262)728-4904 or (800)252-5012

E-mail: wcb@spx.com

For more information about our worldwide locations, approvals, certifications, and local representatives, please visit www.spxfl.com or www.gowcb.com.

SPX Corporation reserves the right to incorporate our latest design and material changes without notice or obligation.

Design features, materials of construction and dimensional data, as described in this bulletin, are provided for your information only and should not be relied upon unless confirmed in writing.

Issued: 10/2010 FH-1725

Copyright © 2000, 2010 SPX Corporation