

SANITARY BUTTERFLY

316L BUTTERFLY SERIES



BFY-316L

FEATURES/SPECIFICATIONS:

- ASTM 316L grade stainless steel material
- Surface finish meets all 3-A, FDA & USDA standards and requirements
- 316L mirror finish disc helps provides an even flow preventing obstructions and restrictions
- The Tru-Flo butterfly valve features a special "opposing" body bolt design that prevents the loosening between body sections due to vibration and usage. This positive sealing prevents the usual leaking and maintenance worries that are common in other sanitary butterfly valves.
- Body bolting is flush with the body's surface preventing obstruction or modifications needing to be made to the valve during actuation or when space is limited for installation
- FDA approved Silicone, EPDM, Viton, and White Viton Seals are available
- Special 304ss 13-position, spring loaded, lever lock handle
- Standard Connections are Tri-Clamp and Butt-Weld. Other end connections are available upon request
- Suitable for actuation with pneumatic, electric and canister actuators
- Pressure - 110 PSI @ 200 degrees F. (Approx. 95C)

Tri-clamp Ends

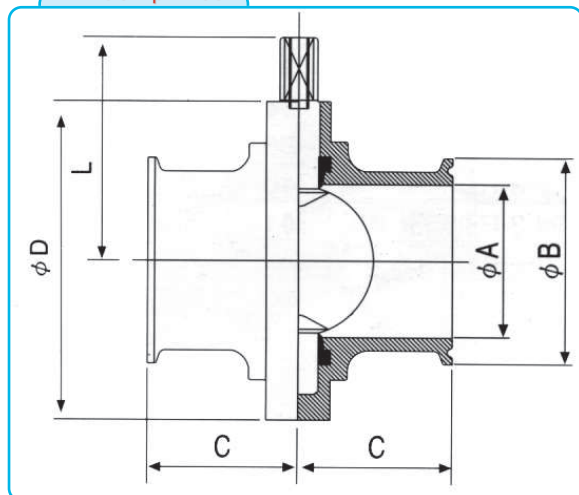

TRI-CLAMP (STANDARD)					
size	A	B	C	D	L
1.0"	22.1	50.5	44.5	79	61
1.5"	34.8	50.5	44.5	85	64.3
2.0"	47.5	64.0	47.6	105	74.3
2.5"	60.2	77.5	48.4	112	77.6
3.0"	72.2	91.0	51.5	125	84.3
4.0"	97.6	119.0	60.8	157	101.6
6.0"	148.3	166.9	76.2	208.3	76.2

Weld Ends

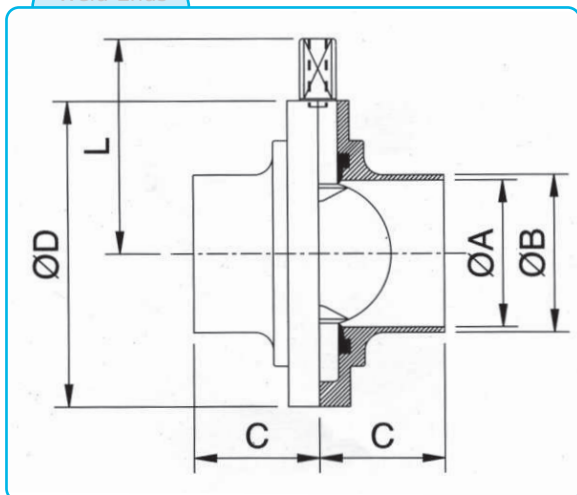

Description	Material	Qty
Body Half	316L	1
Disc	316L	1
Seal	Silicone/EPDM/Viton	1
Body Bolts	304	1
Notch Plate	304	1
Body Cap	Buna	1
Handle Cap	Buna	1
Handle Screw	304	1
13 Position Handle	304	1

SHORT BUTT - WELD (STANDARD)					
size	A	B	C	D	L
1.0"	22.1	25.4	25.4	87.0	61
1.5"	34.8	38.1	25.4	97.0	64.3
2.0"	47.5	50.8	25.4	110.0	74.3
2.5"	60.2	63.5	25.4	110.0	77.6
3.0"	72.2	76.2	31.8	127.1	84.3
4.0"	97.6	101.6	31.8	160.0	101.6

LONG BUTT - WELD (SPECIAL)					
size	A	B	C	D	L
1.0"	22.1	25.4	34	79	61
1.5"	34.8	38.1	38	85	64.3
2.0"	47.5	50.8	40	105	74.3
2.5"	60.2	63.5	40	112	77.6
3.0"	72.2	76.2	41	125	84.3
4.0"	97.6	101.6	44	157	101.6

Note: 6" Weld End also available