

SANITARY EXTEND TUBE BALL VALVE

3-PC SANITARY SERIES



EA - 303 - SN - EXT



FEATURES / SPECIFICATIONS:

- Investment Cast 316L stainless steel construction
- 3-pc split body design facilitates inspection and easy inline repair
- Full port flow to tube I.D./O.D. for sanitary applications
- Highly polished, 8-12 Ra finish for use in food and pharmaceutical applications
- Meets FDA & USDA requirements when used with body cavity fillers
- 3-pc, V-ring "chevron" stem packing for better sealing and lower torque
- Extend Tube butt-weld ends allow easy inline welding without disassembly of valve and are suitable for orbital welding
- Blow out proof, bottom entry stem design
- ISO 5211 Mounting Pad
- Regular and Cavity Filled designs available
- Sizes: 1/2"-2" in 316L Extend Tube Design
2.5"-4" Available in Short Butt-Weld Design

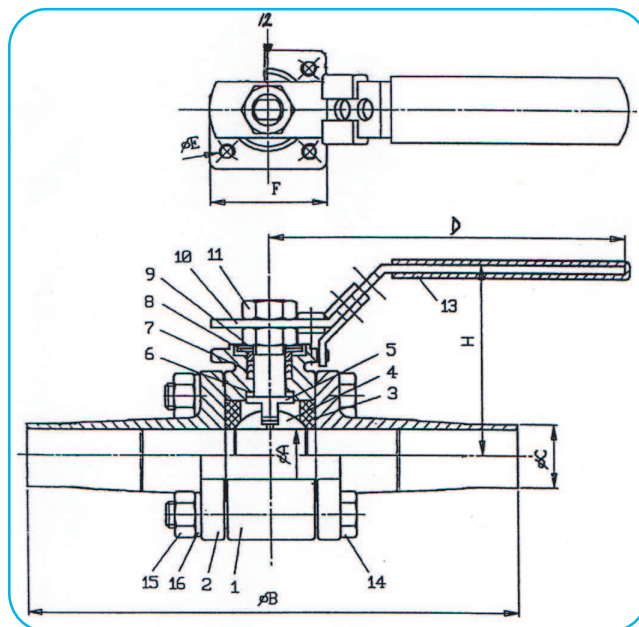

Size	A	B	C	D	E	F	H	weight lbs.	Break Torque in./lbs.
1/2"	0.37	6.00	0.50	4.33	M5x.8	1.42	2.05	2	750
3/4"	0.63	6.00	0.75	4.33	M5x.8	1.42	2.27	3	950
1"	0.87	6.50	1.00	5.31	M5x.8	1.65	2.93	4	150
1-1/2"	1.37	8.00	1.50	6.5	M6x.1	1.97	3.5	7	280
2"	1.87	8.50	2.00	6.5	M6x.1	1.97	3.96	10	385



THE WILLIAMS - CARVER COMPANY, INC.
4001 MISSION RD P.O. BOX #3140
KANSAS CITY, KS 66103-0140
Office [913] 236-4949 Fax [913] 236-9331
www.williams-carver.com

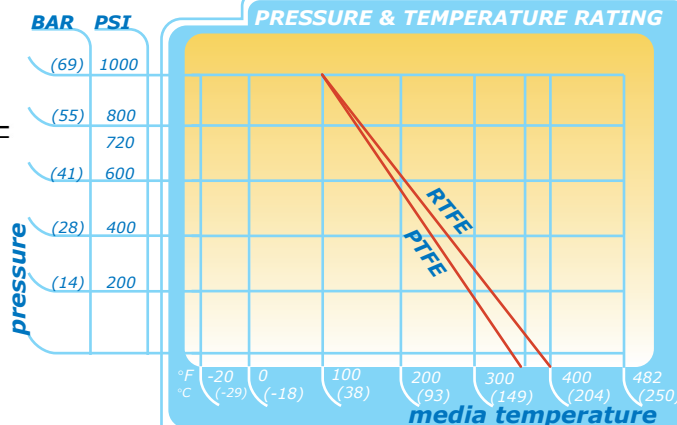

EA - 303 - SN - EXT

Item	Part Name	Material	Qty
1	body	CF8M/316	1
2	end caps	CF8M/316L	2
3	seats	PTFE	2
4	ball	SUS 316L	1
5	stem	SUS 316L	1
6	gasket	PTFE	1
7	seal	PTFE	1
8	gland ring	SUS 304	1
9	Bellville spring washer	SUS 301	2
10	handle	SUS 304	1
11	lever nut	SUS 304	1
12	stop	SUS 316	1
13	plastic coating	PVC	1
14	bolts	SUS 304	4
15	bolts nut	SUS 304	4
16	spring washer	SUS 304	4